

# FPGA - Based Emergency Traffic Light Controller System with IoT Application

Nur Asyakireen Shamsuddin, Siti Lailatul Mohd Hassan\*, Ili Shairah Abdul Halim and Azilah Saparon

School of Electrical Engineering, College of Engineering, Universiti Teknologi MARA, 40450 Shah Alam, Selangor, Malaysia.

\*Corresponding author: sitilailatul@uitm.edu.my

**Abstract:** This paper present the design of a field-programmable gate array (FPGA)-based traffic light controller (TLC) with the internet of things (IoT). This approach controls the traffics problem since traffic congestion is a phenomenon that significantly impacted Malaysia's transportation system, especially for emergency vehicles. This problem has affected emergency transportation such as ambulance to make way at the traffic light intersection, which is always busy. This system was designed using FPGA with an IoT platform. Its give priority to emergency vehicles, especially ambulances at the traffic lights intersections. The two objectives for this project are to design and implement the TLC using FPGA at intersection roads and to notify the current traffic condition more systematically by implementing an IoT part. The IoT application is connected to the emergency vehicles driver, informing them of the current traffics light state. The prototype of this project was simulated using Cyclone V and implemented on a DE-10 Nano board as hardware. As for the IoT part, this project uses an ESP8266 Wi-Fi module. The TLC implementation in this project successfully detected an emergency vehicle and notified the driver of the TLC condition.

**Keywords:** DE-10 Nano FPGA; traffic light controller; emergency vehicles; IoT

© 2021 Penerbit UTM Press. All rights reserved

*Article History: received 25 May 2021; accepted 12 June 2021; published 15 September 2021.*

## 1. INTRODUCTION

Traffic lights can also be described as stoplights, traffic signals or semaphore, signalling technologies at road intersections, pedestrian crossings, and other areas for regulating sustainable traffic flows. Generally, a traffic light has three lights. A green light at the bottom of the signal shows the traffic to continue, yellow light in the centre advises the traffic to slow down and prepare to stop, and the red light at the top shows the traffic to stop [5]. By using conventional coloured lights, traffic lights assign the correct way to road users[1]. Besides promising safe driving at road intersections, traffic signal also is built for more systematic movement of vehicles. A TLC reduces or prevents disputes between various traffic streams called junctions in the shared region.[2]. Traffic light controller provides a set of laws and guidelines to be used by drivers, pilots, train operators and ship captains to prevent accidents and other risks. There are significant drawbacks to conventional traffic control technologies because of traffic timing modifications signal for emergency vehicles [3]. As for that, they have to queue and cannot make their way to the required location.

A conventional traffic light has a major drawback: lack of adjustments in timing for emergency vehicles such as ambulances. Therefore, this research aims to implement a systematic traffic control system capable of controlling and prioritising emergency vehicles—this project prioritises emergency vehicles, especially ambulances, at

the traffic lights intersections. In particular, traffic lights are regulated with a fix-time control system on all primary highways, while the narrower streets are controlled by sensors autonomously. There will be two input sensors: camera (picture) and microphone(sound) at the intersections road. These sensors will detect emergency vehicles from a certain distance and turn the light green.

For this project, the TLC is implemented on the Altera DE-10 Nano FPGA board. FPGA is an integrated circuit (IC) with an array of the same logic cells that the user can program. Many system designs that were previously assembled in custom silicon VLSI are now being applied in FPGA.[4]. The aims of this paper is to proposed an automatic emergency vehicle detection TLC with IoT notification on FPGA board.

## 2. BACKGROUND STUDY

One of the busiest traffic lights in Shah Alam (Section 7), Malaysia, was acknowledged and used as the design reference framework. Figure 1 shows the junction structure at Section 7 consisting of four main roads, and each street is divided into two main routes: straight (North-South) and cross (East-West). A road junction was considered with audio and video sensors placed at the intersection. If an emergency vehicle is detected on one of the junction, the traffic signal for that lane turns GREEN, and the other junction turns RED. This allows only one junction to function during that traffics state.

The same goes for the other junction, which is East-West directions. Whenever emergency vehicles are identified, the traffic signal for that street will be turn green. In this design, the North-South (NS) has the highest priority, followed by the East-West (EW) junction, due to the hospital's location in the North area. The timing for each traffic stage can be modified to suit traffic conditions on each lane.



Figure 1: Structure of the road

The TLC involve two significant parts: (1) a state machine to maintain track of the present and next traffic state, (2) a counter to regulates transitions that occur from one vehicle state to another. The emergency vehicle driver will receive a notification whether they can make way at the intersection without waiting or getting stuck in a jam. The drivers will be notified based on the 2-input of the system based on sound and video that are placed at the intersection.

### 3. METHODOLOGY

#### 3.1 The TLC with IoT

Figure 2 shows a TLC system that includes the 2-input sensors: the image (video/camera) and sound (microphone). For image detection, the system uses blob detection to determine the arrival of an ambulance. For sound detection, the system uses MFCC detection to determine the siren sound of the ambulance for a specific distance. The classification for image and sound detection uses a support vector machine that supervised learning models with associated learning algorithms that analyse data used for classification and regression analysis. When the system accurately detects the ambulance arriving on a specific lane, the traffic light will turn to 'GREEN'.

Once the input is detected and the light turns green, the system will notify the ambulance driver using ESP 8266 Wi-Fi Module, which allows them to make way without the need to stop at the intersection. The driver gets notified by an application called Blynk. Using the application, the driver will know that the current traffic is green on that particular lane, saving time and arriving at the scene right on time.

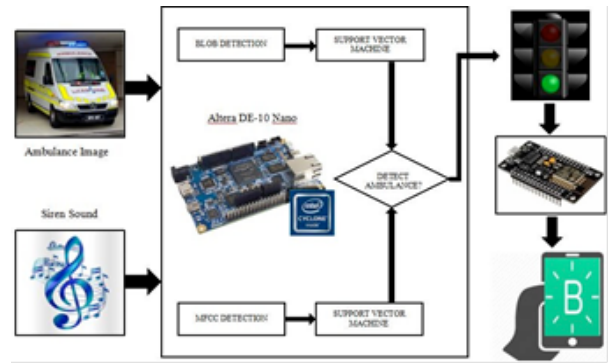

Figure 2: Block diagram of the TLC system

#### 3.2 Flow chart of the TLC system

The flow chart shown in Figure 3 shows the FPGA based TLC system process. The process started when the two sensors placed at the traffic light intersection, which is audio (microphone) sensor and video (camera) sensor, detect an upcoming emergency vehicle at one of the junctions, either North to South or East to West. The process continues as soon the emergency vehicle detected, as shown in the state timing table in Table 2 below.

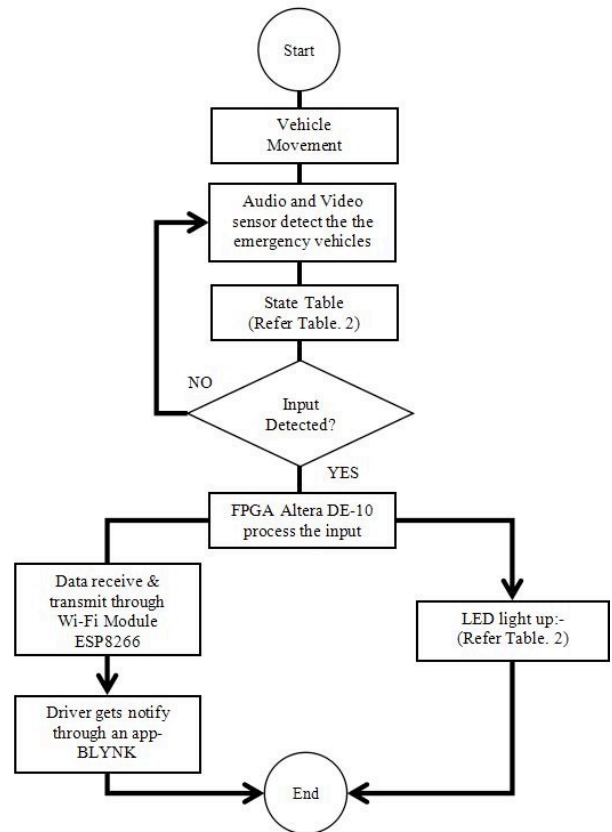

Figure 3: The Flow Chart of TLC System

Table 2. The state table

INPUT		State Description (focus on JA junction)	JA	JB
Video	Audio		North-South	East-West
		All RED signal ON		
0	0	North-South RED		
0	1	North-South GREEN		3s
1	0	North-South RED	3s	3s
1	1	North-South GREEN		

The state table is based on the inputs received at the traffic light to turn green. If no input detected, the traffic light would remain red. There are four states of possible input: (1) both input are at '0', (2) the video sensor is active '1', while the audio is not active '0', (3) the audio sensor is active '1', and the video sensor is '0' and (4) both sensors are detected as active '1'. As the inputs detected, the FPGA Altera DE-10 board will process the inputs, and the LEDs will light up exactly like the actual traffic lights standard colour, which is red, yellow and green. The data received on the current state traffic will be sent through the ESP8266 Wi-Fi Module to the emergency driver to notified and alert whether the junction is safe to go (GREEN) or not. The alert system is on an application called Blynk linked with Wi-Fi Module to transmit the data from the DE-10 Nano board.

4. RESULTS AND DISCUSSION

4.1 Simulation of the TLC system

Timing simulation analysis is used to verify the design. Figure 4 shows that both input sensors, audio and video, are at the '0' state; no inputs are detected. NS will be '100'- RED and EW traffic be '001' - GREEN for this state.

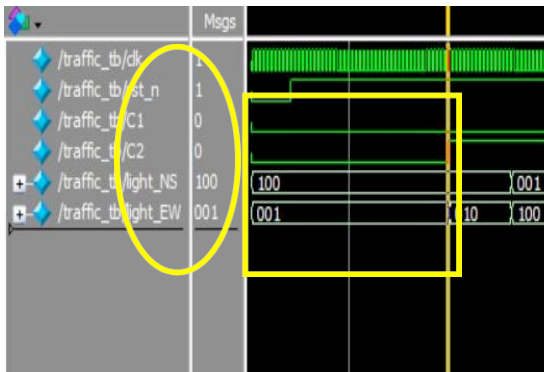

Figure 4: Simulation waveform when both sensors are not active ('0')

Figure 5 shows the next state where the video sensor is at '1' and audio is at '0'. The traffics at NS will be GREEN while EW will be a delay at YELLOW ('010') for 3 seconds, then change to RED' 100'. The delay sets for this project is 3 seconds for the YELLOW state and 10 seconds for the RED state.

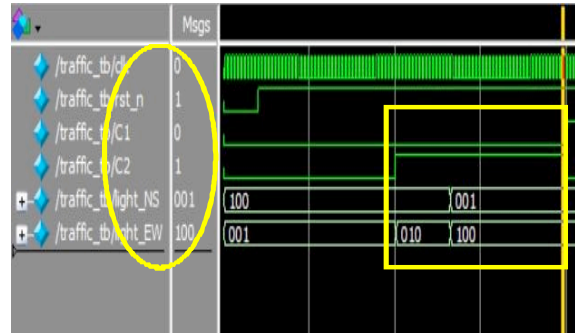

Figure 5: Simulation waveform when sensor C1 is not active('0') and C2 is active('1')

Figure 6 shows the active sensor are the audio sensor at '1' and video sensor at '0'. The NS traffics will delay for 3 seconds to YELLOW then change it to RED. At the EW traffics, the light is YELLOW.



Figure 6: Simulation waveform when sensor C1 is active('1') and C2 not active('0')

Lastly, the timing simulation waveform in Figure 7 shows that both audio and video sensors detect incoming emergency vehicles. The NS traffics are at '001', GREEN, and the EW traffics at '100', RED.

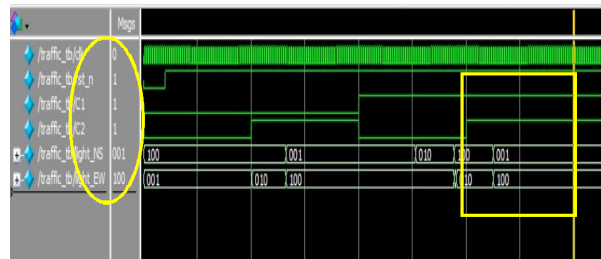

Figure 7: Simulation waveform when both sensors are active ('1')

4.2 Hardware implementation with IoT

The implementation of the TLC system using Altera DE-10 Nano board interfaced using two input sensors: image and audio. Switches are used to represent the image and audio sensor. The design used switch SW1 as an image sensor (C1) and SW2 as an audio sensor (C2). The LEDs act as the mini traffics light based on the selected intersection for this project. Figure 8 shows the LED output when the sensor C1 at '0' and C2 at '0'. The LED at NS turns RED while EW turns GREEN.



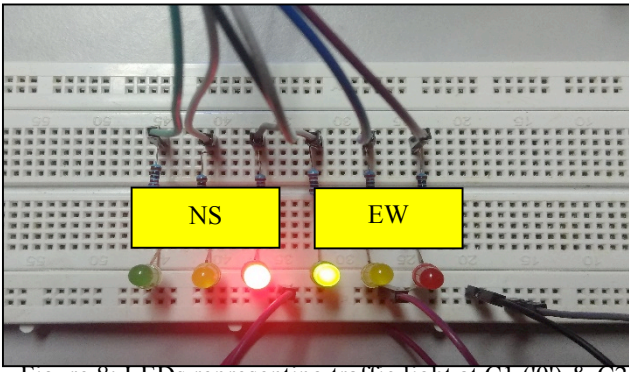

Figure 8: LEDs representing traffic light at C1 ('0') & C2 ('0')

Figure 9 shows C1 is at '0' and C2 at '1'. The LED on NS turns GREEN, and EW turns YELLOW for 3s delay, then turn to RED.

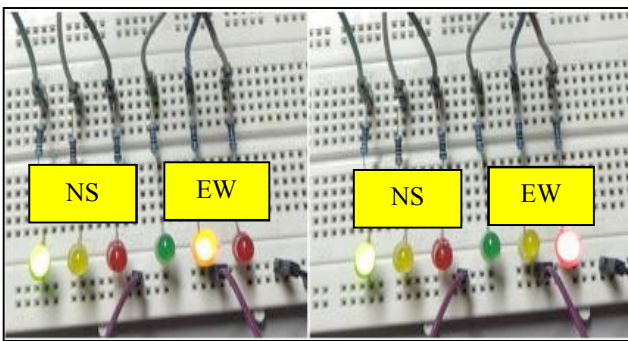

Figure 9: LEDs representing traffic light at C1 ('0') & C2 ('1')

Figure 10 shows the LED at NS turn RED while LED at EW turns YELLOW. It shows that the state was when C1 at '1' and C2 at '0'.

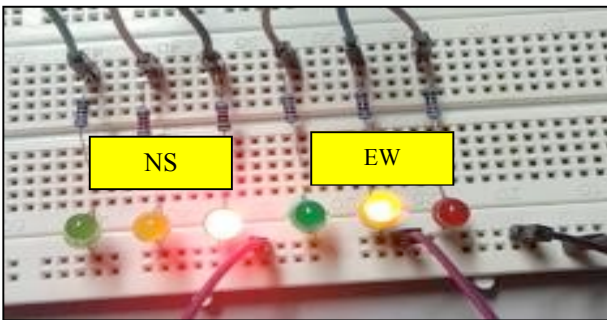

Figure 10: LEDs representing traffic light at C1 ('1') & C2 ('0')

Figure 11 shows the C1 is at '1' while C2 is also at '1'. The LED currently GREEN at NS and RED at EW. Next, the results of the notification on the Blynk application are discussed. This application alert or notify the emergency drivers of the current traffics state ahead.

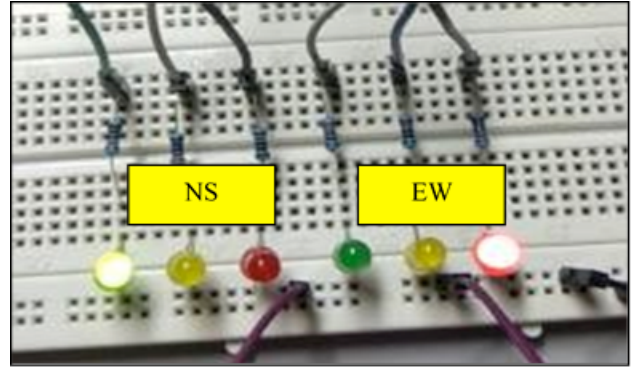

Figure 11: LEDs representing traffic light at C1 ('1') & C2 ('1')

The application notifications in the Blynk application are shown in Figure 8-11. The application is connected to ESP 8266 Wi-Fi Module for data transmission. Figure 12 shows an alert for the state '0'- '0'. The following figure, Figure 13, showed the '0'- '1' state and followed with Figure 14, with reversed output the previous notification. Figure 15 shows the message at '1'- '1' state. This application act as an IoT platform that helped emergency drivers to arrive at the scene more efficiently than the standard system of TLC.

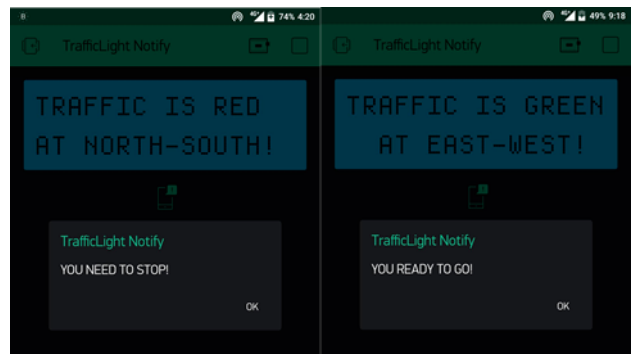

Figure 12: Notification on Blynk at C1('0') & C2 ('0')

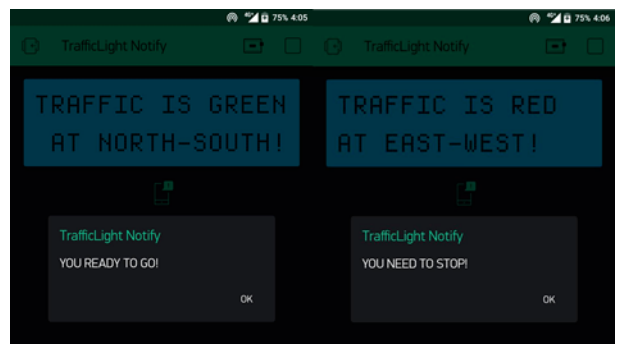

Figure 13: Notification on Blynk at C1('0') & C2 ('1')

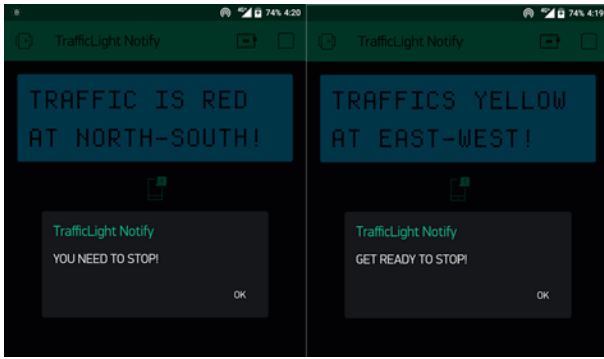

Figure 14: Notification on Blynk at C1('1') &amp; C2 ('0')

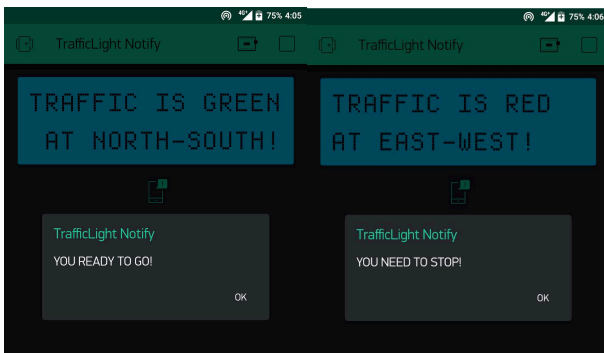

Figure 15: Notification on Blynk at C1('1') &amp; C2 ('1')

## 5. CONCLUSION

This project on TLC for emergency vehicles is very helpful and beneficial for emergency vehicles that required them to move faster significantly in busy areas, without wasting time stuck in a traffic jam and deliver their aid for those needed. The TLC is equipped with two sensors placed at the road intersection to detect the current position of the emergency vehicle. The traffic light becomes green until the ambulance passed by and subsequently recovers to its initial control flow. In addition, the driver of emergency vehicles gets the notification from an IoT platform, the Blynk application that provides the current state of the traffic light. This project is thriving as an initial study to regulated the traffic lights to saves time during emergencies. In the future, the TLC prototype system can be improvised by including all four intersections and at a roundabout traffic light condition. It can also be improved by providing more database on different types of the emergency vehicle, not only locally but internationally.

## ACKNOWLEDGMENT

This material is based upon work supported by the College of Engineering, Universiti Teknologi MARA.

## REFERENCES

[1] M.F.M.Sabri, M.H.Husin, WAWZ.Abidin, K.M.Tay, H.M.Basri, "Design of FPGA-Based Traffic Light Controller System". Dept. of Electronic Engineering, Faculty of Engineering,Universiti Malaysia Sarawak, Sarawak, Malaysia, 978-1- 4244-8728-8/11, 2011.

- [2] El-Medany, W.M., & Hussain, M.R." FPGA-Based Advanced Real Traffic Light Controller System Design". Proceeding of 4th IEEE International Workshop on Intelligent Data Acquisition and Advanced Computing Systems: Technology and Applications, ISBN: 978-1-4244- 1347-8, pg. 100 – 105, 2007.
- [3] D.Bhavana, D.Ravi Tej, Priyanshi Jain, G.Mounika and R.Mohini .Bhavana," Traffic Light Controller Using Fpga", D.Bhavana et al. Int. Journal of Engineering Research and Applications ISSN : 2248-9622, Vol. 5, Issue 4, ( Part -6), pp.165-168, April 2015.
- [4] Chan, S.S., Deshpande, R.S. & Rana, J.G." Design of Intelligent Traffic Light Controller Using Embedded System". Proceeding of 2nd International Conference on Emerging Trends in Engineering and Technology, ISBN: 978-1-4244-5250-7, pg. 1086-1091, 2009.
- [5] Liu, Y. & Chen. X. "Design of Traffic Lights Controlling System Based on PLC and Configuration Technology". Proceeding of International Conference on Multimedia Information Networking and Security 2009, ISBN: 978-0-7695-3843-3, pg.561-563, 2009.
- [6] Kulkarni, G.H. & Waingankar, P.G." Fuzzy logic based traffic light controller". Proceeding of International Conference on Industrial and Information Systems 2007, ISBN: 978-7-4244-1151-1, pg. 107-110, 2007.
- [7] M.Srinivasan, K.Naveen, R.Srivatsan, J.Thanish, K.Ramkumar, "Efficient Traffic Priority Control for Ambulance Clearance". International Journal of Advance Research in Science and Engineering, ISSN 2319-8354, Volume. 07, Special Issue No.02, February 2018.
- [8] B.Naga Mallika, S.Chakri Sreedhar, "Design of High Efficient Traffic Light Controller using Verilog HDL". International Journal of VLSI.System Design and Communication Systems, ISSN 2322-0929, Vol.04, Issue.12, Pages:1412-1415, November 2016.
- [9] Agho Osarenomase, Faisal Sani Bala, Ganiyu Bakare, "Field Programmable Gate Array Based Intelligent Traffic Light System". International Journal of Engineering and Innovative Technology (JEIT), ISSN: 2277-3754, Volume 4, Issue 11, May 2015.