

Development of an Experimental Test Bench for an Electronically Control Fuel Injection System

Mohd Shahrul Nizam A Halim¹, Hazlina Selamat^{1*}, Ahmad Jais Alimin² and Mohd Taufiq Muslim³

¹Centre for Artificial Intelligence & Robotics, Electrical Engineering Faculty, Universiti Teknologi Malaysia

²Faculty of Mechanical & Manufacturing Engineering, Universiti Tun Hussein Onn Malaysia

³Apt Touch Sdn Bhd, Johor, Malaysia

*Corresponding author: hazlina@fke.utm.my

Abstract: Electronic fuel injection (EFI) system is a fuel delivery system that is controlled electronically with an electronic control unit (ECU) used in most modern vehicle's engine. As the fuel injection runs on a vehicle engine, it is difficult to observe the overall behavior of the fuel injection system. A test bench for a 4-cylinder engine is generally developed to run the ECU without the real engine. The development of the test bench described in this paper includes the fabrication of the mechanical model of the test bench, the use of a signal generator for the input signals representing the various signals of an engine and the development of a computer control algorithm for the four-cylinder engine to provide optimum power and fuel efficiency for the engine. The input signal generation of the crankshaft signal and throttle position signal that are similar to the real signal provided by an engine is also discussed. The development of a cost-effective ECU that calculates the suitable amount of fuel to be delivered at correct timings and sequence is also explained. The important part of this paper is the control of the amount of time needed for the injectors to remain open to give the accurate amount fuel injected as well as to control the injection timing of a 4-cylinder engine sequence. The test bench can also be used for several experiments that require the measurement of fuel injected such as fuel injector performance test.

Keywords: 4-Cylinder Engine, Electronic Fuel injection, Engine Management System, Engine Signal Generator, Fuel Measurement Test Bench.

© 2017 Penerbit UTM Press. All rights reserved

1. INTRODUCTION

Fuel injection system (FIS) is the main technology used in the delivery of fuel in internal combustion engines for its high efficiency as it can reduce fuel consumption, and produce lower level of hazardous emission to the atmosphere compared to the carburetor system [1]. To provide an accurate delivery of fuel amount, fuel measurement should be taken and analyzed to check if it provides the required amount without compromising the engine performance. However, fuel injection takes place in an engine and so it is difficult to take the fuel measurement provided by the ECU. This project has been carried out in order to study how a 4-cylinder engine fuel delivery system works for three different injection sequences and how the control system can be used to obtain good performance. The study is divided into two main parts, which are the test bench with engine signal generator and a controller that runs the same process as an ECU for a 4-cylinder engine. The concept of the overall development is illustrated in Figure 1.

2. TEST BENCH DESIGN

The test bench is designed based on a 4-cylinder engine. For an EFI system, there are two types of commonly used fuel system, which are the return-type fuel system and the returnless-type fuel system. Referring to Figure 2, the return-type fuel system consists of a fuel tank for storing

the fuel, electric fuel pump to supply the pressurized fuel to injectors, fuel filter for filtering the fuel from impurities, high-pressure line where the pressurized fuel is transferred, pressure regulator to keep the pressure at certain value, fuel injectors for injecting the pressurized fuel, fuel rail that provide optimal fuel distribution to injectors and return line that send uninjected fuel back to the fuel tank. The difference between the two is that the return-type fuel system has the fuel return line (labelled 8 in Figure 2), which the returnless-type does not have. For the test bench design in this project, the returnless-type fuel system is used as it is simpler to fabricate and does not require the electronic pressure regulator, which can lower the development cost.

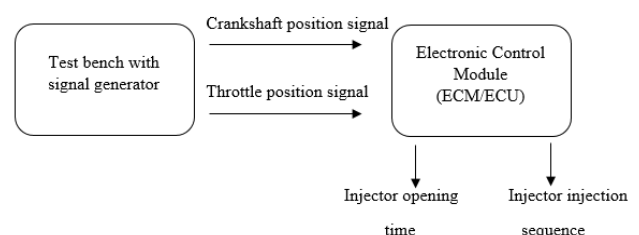

Figure 1. The overall system

The main purpose of this test bench is to run the fuel injection system with observable injection sequence

pattern and to measure the amount of fuel injected for analysis. Hence, the material of the reservoir must be clear or transparent, which allows us to observe the injection event. The material and specification for the design is shown in Table 1.

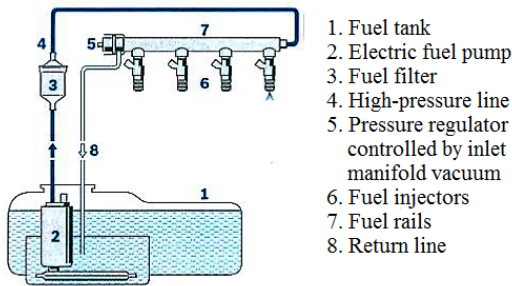

Figure 2. Fuel regulator vacuum controlled system with fuel return.

Table 1. Components and specification

Components	Specification
Main reservoir	Size: 400mm x 138mm Material: Acrylic
Secondary reservoir	Size: 250mm x 138mm Material: Acrylic
Fuel transfer pump	Voltage: 12V Rated current: 1A
Fuel pump	Voltage: 12V Rated current: 1A Maximum pressure: 3 Bar
Injectors	Voltage: 12V Rated current: 1A

The overall test bench design is shown in Figure 3.

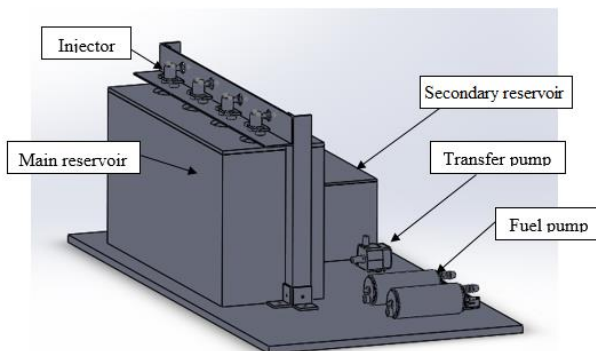

Figure 3. Design of the test bench

2.1 Components and Operations

The top view of the test bench is shown in Figure 4. It consists of a main reservoir that stores the injected fuel for analysis, a secondary reservoir that store the fuel for the fuel pump to supply the pressurized fuel to the injectors, four fuel injectors that inject highly pressurized fuel for combustion process when used in an engine system and two pumps that provides high pressure fuel to the injectors. There is also another pump that transfers fuel from the

secondary reservoir to the main reservoir to be reused (Figure 5).

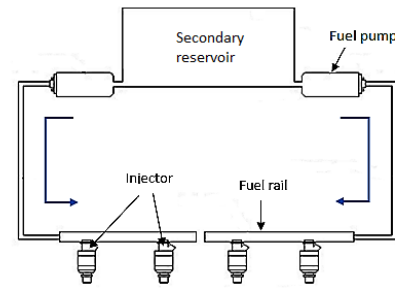

Figure 4. Fuel system concept of the test bench.

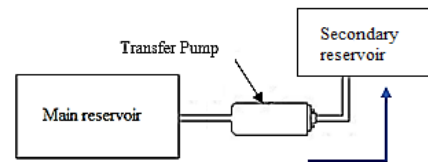

Figure 5. Fuel transfer concept of the test bench.

The test bench system operation begins with the injection of the fuel injectors set for a certain period of time e.g. ten minutes or 600 seconds. The injected fuel that fills the main storage will then be measured and the volume of the fuel is calculated using Eq. (1).

$$\text{Volume, } V(\text{in } m^3 / s) = \frac{\text{Width } (w) \cdot \text{Height } (h) \cdot \text{Length } (l)}{\text{Time } (t)} \quad (1)$$

The quantity of the fuel injected is normally calculated in terms of kilogram per hour (kg/hr). Therefore, the volume obtained in Eq. (1) is converted to kilogram per hour (kg/hr) by using Eq. 2.

$$\text{Flowrate } (W)(\text{in } kg / hr) = \text{Volume } (\text{in } m^3 / s) \cdot 10^{-3} \quad (2)$$

After the fuel measurement was taken, the fuel transfer pump is used to empty the main reservoir by transferring the fuel to the secondary reservoir. The process is repeated if another measurement is to be taken.

2.2 Generation of Simulated Signal

In this part, we discuss the control system of the test bench and how the input signals (crankshaft and throttle positions signals) are generated. Two potentiometers are used to change the simulated values of the throttle position (TPS) and the engine speed (in revolution per minute, RPM); and one button to switch on the transfer pump for clearing the tank. The test bench system flowchart is shown in Figure 6 below.

Generally, the signals from an engine are used to determine the load and speed of the engine. There are three types or classification of inputs usually used in the EFI system, which are the basic inputs, correction inputs, and control inputs [2]. In this work, the type of input used is the basic input that consists of the throttle position signal

and the crankshaft position signal as they are sufficient for fuel rate control and valve timing control.

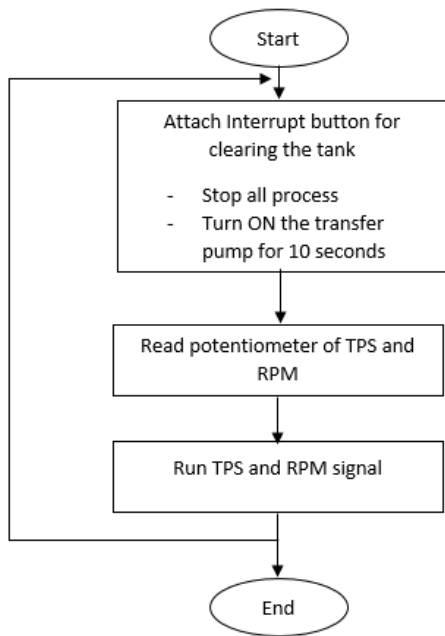

Figure 6. Test bench flowchart.

2.2.1 Throttle Position Sensor

Throttle position sensor is a potentiometer module, which senses the position of the butterfly valve of the carburetor and thus the position of the throttle [3]. The sensor is attached to the throttle body, the place where the air was sucked into the engine. An example of a throttle position sensor is illustrated in Figure 7 below.

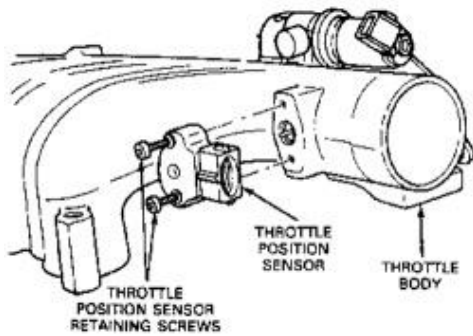

Figure 7. Throttle position sensor [4]

The information from the throttle position sensor is used to control the fuel injection system as it provides the ECU with the load information of the engine to control its performance. Typically, the throttle position sensor provides an analog signal of 0-5V, proportional to the position of the throttle. To generate the throttle position signal, a 10 – kΩ potentiometer is used and the information of the position can be easily translated from 0-5V to 0-90°. The circuit and connection are shown in Figure 8 below.

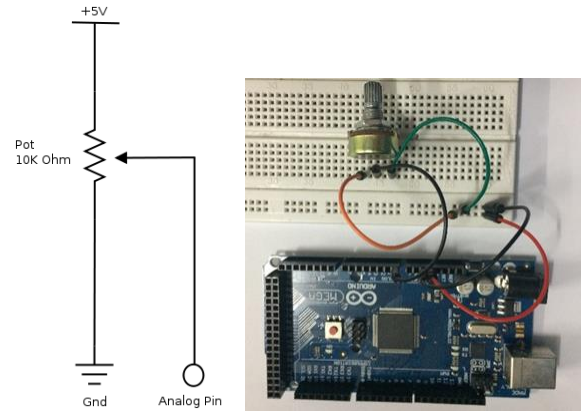

Figure 8. Input potentiometer circuit.

2.2.2 Crankshaft Position Sensor

The crankshaft position sensor is a device that senses the falling edge and rising edge of a rotating trigger wheel (shown in Figure 9) via the magnetoresistance (MR) differences [5]. The signals produced are based on the number of teeth on the trigger wheel. There are several types of trigger wheel, which are the 36-1 (35 teeth and 1 missing tooth), 24-1 (23 teeth and 1 missing tooth), etc. In this work, a 12-1 (11 teeth and 1 missing tooth) is used.

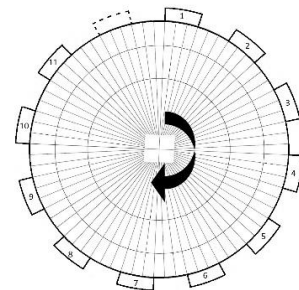

Figure 9. 12-1 trigger wheel

The signal of the 12-1 trigger wheel consists of 11 HIGH pulses of teeth and one missing pulse that used as the reference point correspond to the top dead center (TDC) of the engine cylinder. By knowing the position of the cylinder's TDC, the positions of all the cylinders can be calculated and the stroke that the engine is in can be determined. The signal of the 12-1 trigger wheel that is being fed to the ECU has the features shown in Figure 10.

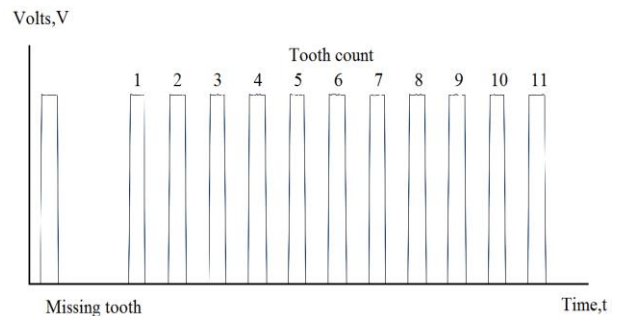
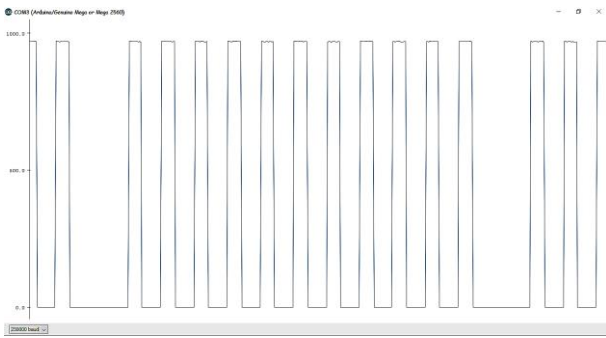

Figure 10. An example of the 12-1 trigger wheel signal

To generate the signal, an Arduino UNO is programmed

to give exactly 11 pulses and 1 missing pulse. By using the serial plotter in Arduino IDE software, the results of signal produced at several speeds (RPM) were recorded and shown in Figure 11.



(a)

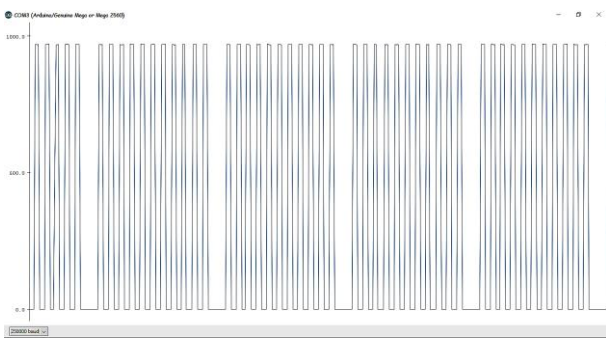

(b)

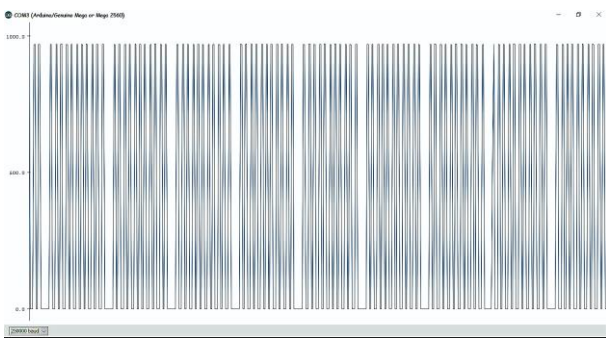

(c)

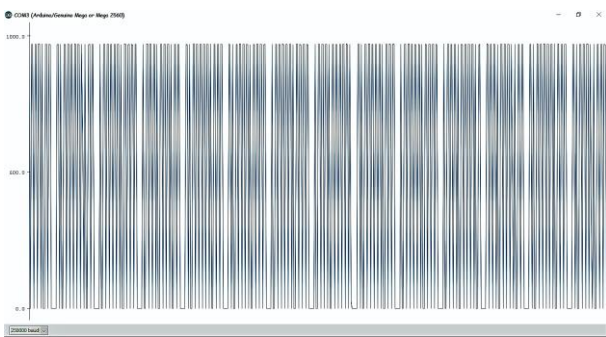

(d)

Figure 11. Results of crankshaft position signals produced at (a) 800RPM (b) 2500RPM (c) 5000RPM (d) 7000RPM

The calculation of RPM from the measured high pulse duration is made using Eq. (6) and the results are shown in Table 2 below.

Table 2. Calculated RPM at several speeds (RPM)

Desired RPM	Measured high pulse duration (μs)	Calculated RPM
62	39708	62.96
125	19856	125.91
250	9930	251.76
500	4967	503.32
1000	2483	1006.85
1500	1665	1501.50
2000	1241	2014.50
2500	995	2512.56
3000	828	3019.32
3500	711	3516.17
4000	620	4032.25
4500	555	4504.50
5000	491	5091.65

2.3 Electronic Control Module

A controller or an Electronic Control Unit (ECU) works as a brain in most modern vehicle engines. There are various variables such as speed, temperature, pressure and pilot throttle used as inputs to the ECU to ensure the required fuel flow is achieved [6]. The ECU is primarily responsible for four main tasks, which are to control the fuel mixture, idle speed, ignition timing and valve timing [7]. Its main objective is to determine what, when, why and how long certain operations needs to be controlled while maintaining the fuel mixture according the stoichiometry air to fuel ratio of 14.7:1 [8].

In this work, the controller is implemented using the open source Arduino MEGA and the coding is done using C. The design of the system is divided into an RPM counter, measurement and calibration, fuel rate control and multi-injection control as shown in Figure 12 below.

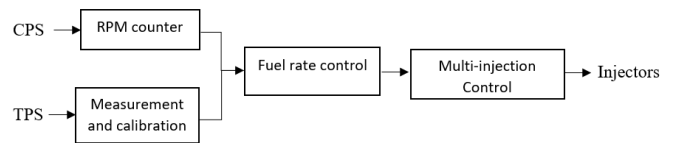

Figure 12. Design overview of the system

2.3.1 RPM Counter

Speed in an ECU is calculated in terms of revolutions per minute (RPM), which is the number of complete rotations (360°) of the crankshaft in one minute. To obtain the current speed of the crankshaft, the frequency of the crankshaft is calculated by dividing the time taken to complete one rotation of the crankshaft. The frequency in Hz (s⁻¹) is then is simply converted to RPM by multiplying by 60.

$$\text{Frequency } (f) = \frac{1}{\text{Time } (t) \text{ in } s} \tag{3}$$

$$\text{Speed in } RPM = 60 \times \text{Frequency in } 1/s \tag{4}$$

On the RPM counter, the crankshaft signal (CPS) is read and the data are processed to obtain the number of teeth and the RPM reading. Firstly, the number of teeth counting

begins with the detection of the rising edge of the signal right after the LOW pulse of the missing tooth. The first number of tooth, which is 1, is the 0° reference point of the crankshaft and the next number of tooth means the increasing of 30 degrees of rotation. The maximum number of tooth count is 22 which represented the 660°. Table 3 below shows the tooth count and the angle of crankshaft it represents.

Table 3. TPS angle represented

Tooth count	Angle (°)
1	0
2	30
3	60
4	90
5	120
6	150
7	180
8	210
9	240
10	270
11	300
12	360
13	390
14	420
15	450
16	480
17	510
18	540
19	570
20	600
21	630

To calculate the speed (RPM), the frequency of one complete rotation is needed. The frequency is calculated using the time of rising pulse or pulse width duration. The total time for one complete rotation can be estimated by using the pulse width for one pulse multiply to 24 since it has 11 positive pulses and 13 zero pulses. The engine speed in RPM is then calculated by multiplying the frequency by 60 using the formula

$$\text{Frequency } (f) = \frac{1}{24 \cdot \text{pulsewidth}} \quad (5)$$

$$\text{Speed in RPM} = 60 \cdot \text{Frequency in 1/s} \quad (6)$$

2.3.2 Measurement and Calibration

This part converts the raw analog reading to the usable data. It is a very important part as it prevents the false value or negative value if the throttle is out of range due to the possibly non-fixed reference point on the screw type sensor used. The TPS data can be directly read from the potentiometer and converted by changing the 10-bit value ranging from 0-1023 into 0-90 degree rotation values.

2.3.3 Fuel Rate Control

There are three fuel control methods used in the EFI system. The method used is defined by the types of sensors used in the EFI system. The *Alpha-n* method requires only the TPS reading as the indicator of load measurement. On the other hand, the *speed-density* method requires the use of the TPS sensor and the manifold absolute pressure (MAP) sensor, whereas the mass air flow method requires the mass airflow (MAF) sensor. In the work described in this paper, the *alpha-n* method is used, where as the throttle angle increases, the amount of fuel injected will also be

increased. This method does not measure the air flow directly, but using the throttle angle (alpha) versus the engine speed (n) lookup table programmed by the tuner with the amount of fuel needed at each point [9].

The fuel rate control ensures that the correct time for the injectors to remain open in order to achieve the ideal air-to-fuel ratio of 14.7:1. As the values of the current engine speed and TPS are known, the pulse width or duration of injection can then be directly obtained from the programmed lookup table. An example of the lookup table is shown in Figure 13 below. The value in the table is due to the 256 prescaler and the exact value of the timing can be calculated by value in the table multiplying 16 μs since the raise 1 equal to 16 μs.

RPM	0	500	1000	1500	2000	2500	3000	3500	4000	4500	5000
TPS											
0	363	363	363	363	363	363	426	426	426	363	363
10	238	238	176	176	176	176	176	176	176	176	176
20	238	238	176	176	176	176	176	176	176	176	176
30	238	238	176	176	176	176	176	176	176	176	176
40	176	176	176	176	176	176	176	176	176	176	176
50	176	176	176	176	176	176	176	176	176	176	176
60	176	176	176	176	176	176	176	176	176	176	176
70	176	176	176	176	176	176	176	176	176	176	176
80	176	176	176	176	176	176	176	176	176	176	176
90	176	176	176	176	176	176	176	176	176	176	176

Figure 13. Example of a 2D fuel map for *Alpha-n* method

2.3.4 Multi-injection Control

In controlling a 4-cylinder engine, Multi-Port Fuel Injection (MPFI) is preferred. The MPFI is a system or method of injecting the fuel to separate injectors of each cylinder. Each of these injectors is controlled by a microprocessor to deliver an exact quantity of fuel in each cylinder at the right time [10]. There are three types of MPFI system – ‘simultaneous’ where all cylinders have the same injection timing, ‘batched’ where the cylinder injection timing divided into the group or batches and ‘sequential’ where each cylinder have different injection timing for one complete cycle of the 4-stroke (720° of crankshaft rotation) [11]. In this work, the sequential system with 1-3-4-2 firing order is used. In order to control the injection timing precisely, the typical four-stroke engine cycle is studied and the overall concept can be illustrated as in Figure 14.

The multi-injection control is responsible in providing the pulse width modulation (PWM) signals to all the injectors. To implement the sequential injection, the timing of when to begin the injection is crucial. In a 4-stroke engine, there are four different cycles known as the intake, power, compression and exhaust cycles. The most important stroke in determining the injection timing is the intake stroke. Since the fuel must be ready to be injected before the intake stroke, the exhaust stroke is used as the injection starting point. By referring to the Figure 14 above, we can conclude that the injection of the first cylinder occurs at 540°, the second cylinder at 360°, the third cylinder at 0°, and the fourth cylinder at 180°, which are the exhaust stroke of all the cylinders. For the controller, the number of teeth read from the crankshaft signal is 22 tooth for two revolutions (720°) of rotation. So, the injection for cylinder one is triggered at tooth number 18, injection for cylinder two at tooth number 12, injection

for cylinder three at tooth number 1 and injection for cylinder four at tooth number 7.

	0° TDC	180° BDC	360° TDC	540° TDC	720° TDC
Cylinder 1	Intake	Compression	Power	Exhaust	
Cylinder 2	Compression	Power	Exhaust	Intake	
Cylinder 3	Exhaust	Intake	Compression	Power	
Cylinder 4	Power	Exhaust	Intake	Compression	

Figure 14. Four stroke engine cycle

3. USING THE TEST BENCH

The test bench is designed as an experimental platform to understand the process of an EFI system for a 4-cylinder engine. It takes the measurement of the injected fuel and allows the fuel delivery process to be monitored and understood for fuel map tuning purpose, as an example. By measuring the fuel injected, the test bench can also be used for fuel injector and fuel pump performance tests since difference injectors and pumps have different characteristic.

The experiment involves the following steps: firstly, the speed of the crankshaft signal and throttle position signal are set by the user. As the injection start, the time duration of the injector's opening time is measured. To calculate the volume of fuel injected in the main reservoir, the height of the rectangular prism that is filled by the fuel is measured the total volume of the fuel injected can be calculated using Eqn (1) and (2). After the fuel measurement has been taken, the fuel transfer pump is activated by pressing the button to empty the main reservoir by transferring the fuel to storage reservoir. The process is repeated if another measurement is to be taken.

Table 4 shows the result of the measured fuel for five different speeds.

4. CONCLUSION

Multi-Port Fuel injection (MPFI) system is an electronic system that delivers a precise amount of fuel to each cylinder at the right time. In order to observe the overall behavior of the fuel injection system either the sequence of injection or injected amount, a test bench with input signal generator to provide simulated engine input signals and a controller for the 4-cylinder engine has been designed and fabricated. The injection sequence can be clearly seen from the test bench and the fuel rate can be tuned by changing the values in the lookup table. The fuel injection measurement can also be used as the reference to analyze whether the fuel demand is fulfilled.

As a conclusion, the controller for the EFI system of a 4-cylinder engine has been successfully developed. However, many improvements can be made for future works, especially the lookup table development to achieve highly-efficient fuel usage for the engine, preventing excessive fuel consumption, and lowering the level of

hazardous emission to the atmosphere.

Table 4. TPS angle represented

Speed (RPM)	TPS (°)	Opening time from lookup table (ms)	Injected fuel recorded (nm ³ /s)
1000	80	2.816	57.79
2000	80	2.816	446.72
3000	80	2.816	472.80
4000	80	2.816	606.76
5000	80	2.816	693.44

ACKNOWLEDGMENT

The authors would like to thank Universiti Teknologi Malaysia and the Ministry of Higher Education Malaysia for their supports. The project is funded by Research University Grant 13H78.

REFERENCES

- [1] Hassani, A. and V. Hosseini, "An assessment of gasoline motorcycle emissions performance and understanding their contribution to Tehran air pollution", *Transportation Research Part D: Transport and Environment*, 2016. 47: pp. 1-12.
- [2] Abdo, E., *Modern Motorcycle Technology*. Vol. Second Edition. 2013, United State, America: Cengage Learning.
- [3] Overcash, D.A., L.E. Hall, and G.W. Mueller, "Throttle position sensor", 1986, Google Patents.
- [4] "2002 Ford Explorer: 2002 Ford Explorer How Do I Install Tps Where ...", *2carpros.com*, 2017. [Online]. Available: <https://www.2carpros.com/questions/2002-ford-explorer-2002-ford-explorer--4>. [Accessed: 29May-2017].
- [5] Schroeder, T., "Crankshaft position sensor", 2002, Google Patents.
- [6] Aziz, A., "Electronic control unit (ECU) development of a fuel injection system", in Thesis (Sarjana Kejuruteraan (Elektrik - Mekatronik dan Kawalan Automatik)) - Universiti Teknologi Malaysia, 2013. 2013, Universiti Teknologi Malaysia.
- [7] Surnilla, G., H.B. Gangwar, and S.B. Smith, "Lean idle speed control using fuel and ignition timing", 2005, Google Patents.
- [8] *Hartman, J., How to Tune and Modify Engine Management Systems, 2004: Motorbooks.*
- [9] Wade, A., *Motorcycle Fuel Injection Handbook*, MotorBooks International. Ulrich, M. and B. Fisher, *Holley: Carburetors, Manifolds and Fuel Injection*. 1994: HP Books.
- [10] Houston, R.D. and G.F. Chatfield, "Engine management system", 2003, Google Patents.
- [11] Rathore, V.D., "Use of CRDi/MPFi Technology in Automobiles", *International Journal of Scientific & Engineering Research*, 2015. 6(6): pp. 1211-1213.