

# Analysis of Different Nanostructures of ISFET Biosensors Towards Liposome Detection

Lam Yi Ling, Suhana Mohamed Sultan\* and Nur Afiqah Ab Razak

Faculty of Electrical Engineering, Universiti Teknologi Malaysia, 81310 UTM Skudai, Johor, Malaysia.

\*Corresponding author: suhana@fke.utm.my

**Abstract:** Proteins are needed by all living cells for structural and functional purposes. However, some proteins such as liposome instability may result in medication leaks that could harm cells. The detection of liposomes is dependent on the complex interactions between proteins, which are necessary for both their structural integrity and functional characteristics. This emphasizes the critical role that proteins play in the precise identification and examination of liposomal structures. Ion-sensitive field-effect transistor (ISFET) biosensor has gained popularity in the clinical research field for biomolecule detection due to its high detection sensitivity, mass-production capability, and low manufacturing cost. Nanohub BioSensorLab software was used to analyze the performance of different structures of ISFET (planar, cylindrical nanowire, nanosphere and double-gate FET) by simulating the settling time and selectivity of the biosensors. As the structural dimension expands from 1D to 3D, the settling time increases by three folds at the lowest analyte concentration. The fastest settling times were achieved by planar ISFET and double-gate FET. For selectivity measurements, an enhanced selectivity was achieved by increasing the concentration of the target molecule and decreasing the concentration of the parasitic molecule. A higher selectivity is determined by the higher Signal-to-Noise Ratio (SNR) value. The SNR increased linearly corresponds to the increase in the concentration of the target molecule as well as the decrease in the parasitic molecule's concentration. The parasitic molecule's size increase of 1 nm causes a rise in SNR of  $5.00 \times 10^3$ .

**Keywords:** Cylindrical nanowire, Double-gate FET, Liposome, Nanosphere, Planar ISFET

© 2024 Penerbit UTM Press. All rights reserved

Article History: received 29 January 2023; accepted 13 July 2023; published 28 April 2024.

## 1. INTRODUCTION

In recent years, biosensor has gained popularity in clinical treatment, pharmacy, biomedical and healthcare sectors due to their ability to ensure public safety while delivering health services to patients [1]. There are many types of deadly diseases in the world, including those that are fast-acting and those that progress slowly. For example, coronary artery disease (CAD), is one of the heart diseases that caused 8.8 million deaths in the year 2015; and is a slowly progressed disease that is caused by various factors, such as, high blood pressure, high cholesterol, and diabetes [2]. Besides, the recent outbreak of the disease, COVID-19 has infected more than 340 million people worldwide and caused over 5.6 million deaths [3]. Furthermore, proteins are needed by all living cells for structural and functional purposes. However, excessive intake or misuse of proteins can have a negative impact on the human body. For example, the accumulation of saturated fat and cholesterol in the kidney or liver [4].

A biosensor can be used in the detection of DNA, proteins, enzymes, and cells, which can aid in the clinical diagnosis of diseases. Improved biosensor technology qualities allow the ability to detect disease and track the body's response to care [1]. It is critical to detect and diagnose infections, to prevent the virus from spreading to all body cells. Early therapy may increase the chances of a

successful recovery. Hence, an efficient and effective biosensor should be a technology worth investing in.

Protein is a chain of amino acids that plays an important part in the human body. Protein is crucial for the regulation of body tissues and organs, the repair of body cells, and the growth and development of the human body, particularly in children and teenagers [5]. For example, liposome is used in the medical field for drug delivery purposes due to their ability to encapsulate hydrophobic or hydrophilic drugs. However, the degradation of liposomes will result in the formation of undesired degradants such as free fatty acids, reactive oxygen species (ROS), aldehydes and cholesterol derivatives, which will have harmful effects on cells or tissues. Besides, the instability of liposomes will cause drug leakage [6].

Ion-sensitive field-effect transistor (ISFET) is a popular biosensor technology. It is commonly employed in biomedical applications to track biological processes such as protein-protein interactions, DNA hybridization, glucose measurement, potential of hydrogen (pH) sensing and antigen-antibody binding [7]. ISFET consists of bioreceptors that will recognize and bind only to the target molecules. Examples of receptor molecules are enzymes, cells, DNA, and antibodies. ISFET is immersed in the electrolyte, which serves as a buffer solution containing both electrically conducting target biomolecules and other molecules. The reference electrode is used to adjust the

bulk electrolyte potential. The binding and interactions between target molecules and receptor molecules modulate the conductance of ISFET [8]. However, there are several limitations of ISFET, such as a lack of good solid-state electrodes, parasitic sensitivity to temperature and light, and time-dependent instability of sensor parameters. The adoption of fluorescent labeling and parallel optical detection techniques were expensive and time-consuming ways of improving the ISFET performance [9]. To achieve fast detection of biomolecules with low concentration, enhancement of the structure of ISFET biosensor, such as increasing the surface-to-volume ratio could be a better approach. This study aims to investigate how liposomes affect the functionality of various ISFET biosensor nanostructures as well as to evaluate the selectivity and settling times of ISFET biosensors with various nanoelectronics structures.

## 2. BIOSENSOR SIMULATION

### 2.1 Design Parameters

Table 1. Parameters of different ISFET's structures

	No	Parameters	Values
Planar	1	Oxide thickness (nm)	1
	2	Length (nm)	30
	3	Width (nm)	1000
Cylindrical Nanowire	1	Radius (nm)	100
	2	Oxide thickness (nm)	10
Double-gate FET	1	Device width (um)	10
	2	Device length	1
	3	Silicon body thickness (nm)	8000
	4	Top oxide thickness (nm)	4
	5	Back oxide thickness (cm)	15000

Table 1 shows the nanostructure design parameter for planar, cylindrical nanowire and double-gate FET biosensors. The selection of parameters is based on the best-case scenario to optimize the performance of the biosensors in order to obtain the highest sensitivity.

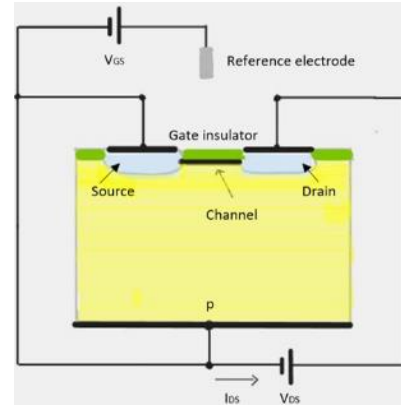

Figure 1. General ISFET's structure

### 2.2 Simulation Parameters

Table 2. Parameters for settling time

		Parameters	Values
Settling Time against Analyte Concentration	1	Lower value of analyte concentration (molar unit)	0.00533
	2	Upper value of analyte concentration (molar unit)	0.016
Time-Dependent Capture of Target Molecule	1	Analyte Concentration	0.001

Table 2 shows the parameters for settling time. Settling time is one of the important parameters in evaluating the performance of biosensors on protein detection. Settling time is the time taken by the sensor to produce a stable signal change [10]. The diffusion coefficient of liposome in collagen is set to be at  $25 \times 10^{-8} (cm^2/s)$ [11]. The settling time is simulated using nanoHUB BioSensorLab [12].

Table 3. Parameters for selectivity of biosensor

Parameters	Values
Size of receptor molecules (nm)	1
	2
	3
Size of parasitic molecules (nm)	1
	2
	3

Concentration of target molecules (M)	$1 \times 10^{-15}$
	$1 \times 10^{-12}$
	$1 \times 10^{-10}$
Concentration of parasitic molecules (M)	$1 \times 10^{-9}$
	$1 \times 10^{-6}$
	$1 \times 10^{-3}$

Table 3 shows the parameters for the selectivity of the biosensor. When one of the parameters in Table 3 is varied, other parameters were fixed to the default values. The default values for the size of receptor molecules, size of parasitic molecules, the concentration of target molecules and concentration of parasitic molecules are 2nm, 1nm,  $1 \times 10^{-12}$ M and  $1 \times 10^{-6}$ M, respectively.

## 2.3 Results and Discussion

### 2.3.1 Analysis of settling time and analyte concentration

Figure 2 shows that the planar ISFET and double-gate FET biosensors have the same settling time, and both consumed the least amount of time to detect protein molecules. Followed by the cylindrical nanowire biosensor. Nanosphere biosensor has the longest settling time. The different structures of biosensors significantly impact the settling time.

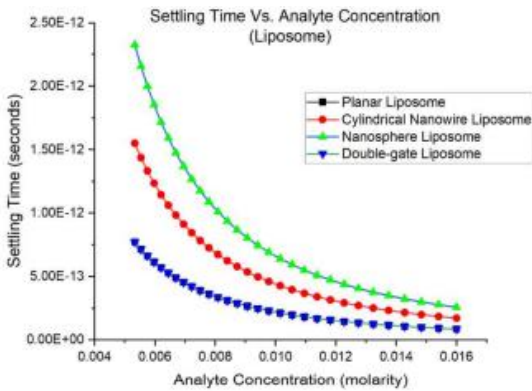
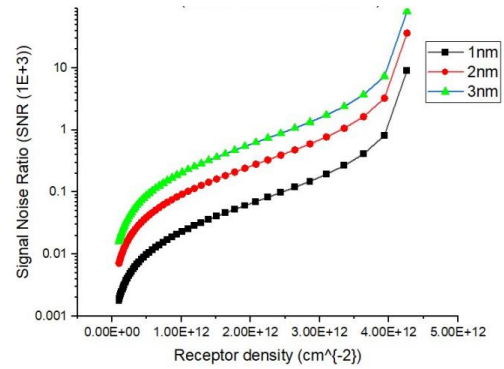

Figure 2. Settling time vs analyte concentration (liposome)

Planar ISFET biosensor is considered as a one-dimensional (1D) structure, cylindrical nanowire biosensor has a two-dimensional (2D) structure, and nanosphere biosensor has a three-dimensional (3D) structure. As the structure's dimension grows, target biomolecules will interact with the biosensor in a more multi-directional manner. This will cause instability and would need a longer time to produce a stable output signal change in the biosensor. The double-gate FET can be categorized as a 1D structure as the surface is the same as planar ISFET. Interactions with target protein molecules follow the same pattern. As a result, the settling time is identical to that of a planar ISFET biosensor.

### 2.3.2 Selectivity: Signal-to-noise ratio (SNR)

There are several factors affecting the selectivity of biosensors, which are the size of receptor molecules and parasitic molecules, as well as the concentration of target molecules and parasitic molecules.



(a)

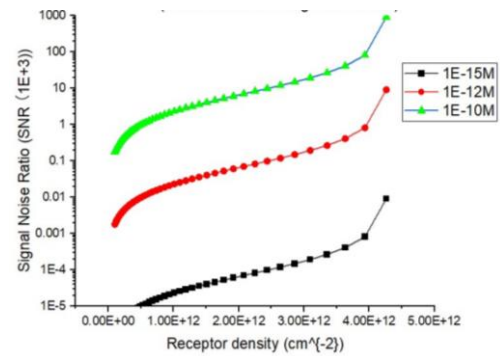

(b)

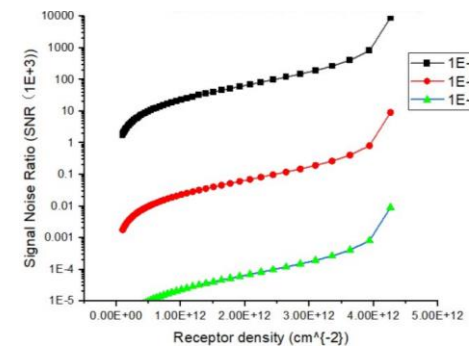

(c)

Figure 3. SNR against (a) size of parasitic molecules; (b) concentration of target molecules; (c) concentration of parasitic molecules

From the results obtained, the SNR is not affected by the types of nanostructures; planar ISFET, cylindrical nanowire, nanosphere and double-gate FET. The selectivity of biosensors corresponds to the size of parasitic molecules, the concentration of target molecules and parasitic molecules. High SNR indicates high selectivity,

where high selectivity can be achieved by increasing the concentration of target molecules and parasitic molecules. On the other hand, the concentration of parasitic molecules must be reduced to improve performance.

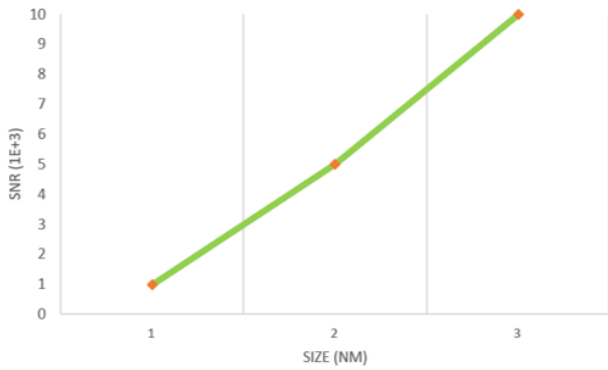

Figure 4. SNR against the size of parasitic molecule at receptor density of  $4.00 \times 10^{12} \text{ cm}^{-2}$  and receptor molecules's size of 2nm

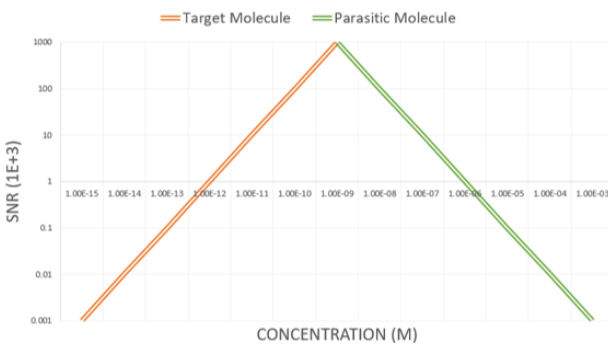

Figure 5. SNR against the concentration of target molecule and parasitic molecule at receptor density of  $4.00 \times 10^{12} \text{ cm}^{-2}$

Based on Figure 4, the SNR is affected by the size of the parasitic molecule. The increase in the size of the parasitic molecule by 1 nm results in the increase of SNR by  $5.00 \times 10^3$ . Figure 5 shows that at the same receptor density, the SNR can be increased linearly by increasing the concentration of the target molecule. In contrast to that, the parasitic molecule's concentration should be decreased to achieve a higher SNR; where it also behaves in a linear configuration.

The parasitic molecule's characteristics play an important role in achieving a better selectivity of the biosensor [13]. It can be accomplished by increasing its size and lowering its concentration, which leads to higher SNR value.

The SNR is a measure of the ratio of signal power to the background noise power. A high SNR value indicates that the biosensor has a high ability to capture the desired signal that gets affected by the incoming target biomolecules. This measurement is important as it shows how well the biosensor performs in the presence of other parasitic biomolecules, where in actual situations the sample solution will not always be pure.

Along with the increased concentration of target molecules and decreased concentration of parasitic molecules, more target molecules exist in the analyte solution. It is easier for the biosensor to identify and capture the target biomolecules. Furthermore, the larger size of parasitic molecules indicates a slower rate of molecular diffusion. As a result, target molecules would diffuse at a faster pace than parasite molecules which explains the raise in selectivity. Next, as the size of receptor molecules grows, greater distance between the valence shell and nuclei. Stronger interaction and bonding can be formed between the valence electrons of receptor molecules and target molecules. Therefore, the selectivity is increased.

From the results obtained, an increase in the analyte concentration indicates a smaller settling time. This is in line with the increase in SNR. Meanwhile, when we increase the dimension of nanostructures, the settling time will be significantly reduced. However, it does not affect the SNR. Therefore, the 1D nanostructure can give the most stable liposome sensing performance.

### 3. CONCLUSION

The settling time increases as the structure dimension grows. Planar ISFET and double-gate FET had the shortest settling time as both are one-dimensional (1D) structures. The three-dimensional (3D) structure of the nanosphere biosensor consumed the longest settling time. Additionally, as the analyte concentrations increased, the settling time shrank as well.

High selectivity of biosensors can be obtained by increasing the concentration of target molecules, size of parasitic molecules and receptor molecules. In addition, minimizing the concentration of parasitic molecules further enhances the performance of the biosensor. According to the findings, the selectivity is unaffected by the biosensor's structural characteristics.

### ACKNOWLEDGMENT

This work was supported by the Ministry of Higher Education under Fundamental Research Grant Scheme (FRGS/1/2018/TK04/UTM/02/41) with UTM cost center no. R.J130000.7851.5F053.

### REFERENCES

- [1] A. Haleem, M. Javaid, R. P. Singh, R. Suman and S. Rab, "Biosensors applications in medical field: A brief review," *Sensors International*, 2021.
- [2] A. Pietrangelo, "The Top 10 Deadliest Diseases," *HEALTHLINE MEDIA*, 2019.
- [3] World Health Organization, [Online]. Available: <https://covid19.who.int/>. [Accessed 21 January 2022].
- [4] I. Delimaris, "Adverse Effects Associated with Protein Intake above the Recommended Dietary Allowance for Adults," *PubMed Central (PMC)*, Volos, Greece, 2013.
- [5] M. Bridges, "Protein in diet," *MedlinePlus*, Charlottesville, 2021.
- [6] "WikiLectures," 11 December 2015. [Online]. Available:

- [https://www.wikilectures.eu/w/Liposomes\\_as\\_drug\\_carriers](https://www.wikilectures.eu/w/Liposomes_as_drug_carriers). [Accessed 12 January 2022].
- [7] C.-S. Lee, S. K. Kim and M. Kim, "Ion-Sensitive Field-Effect Transistor for Biological Sensing," *Sensors*, 2009.
- [8] Y. Wang and G. Li, "Simulation of a Silicon Nanowire FET Biosensor for Detecting Biotin/Streptavidin Binding," Korea, 2010.
- [9] M. Munna, M. O. Islam, M. Kabiruzzaman and Z. H. Mahmood, "Performance Analysis of a Si-NW Biosensor for Detection of Charged Biomolecules," 2014.
- [10] P. Nair, J. Go and M. Alam. [Online]. Available: [https://nanohub.org/resources/20854/download/User\\_Manual\\_1.pdf](https://nanohub.org/resources/20854/download/User_Manual_1.pdf). [Accessed 9 January 2022].
- [11] E. O. Osidak, M. S. Osidak, M. A. Akhmanovac and S. P. Domogatskii, "Collagen—A Biomaterial for Delivery of Growth Factors," *Russian Journal of General Chemistry*, vol. 84, pp. 368-378, 2014.
- [12] P. R. Nair, J. Go, G. J. Landells, T. R. Pandit, M. Alam, X. J. P. Dak and A. Jain, "nanoHUB," 19 August 2014. [Online]. Available: <https://nanohub.org/resources/senstran>. [Accessed 20 December 2021].
- [13] P.R. Nair and M.A. Alam, "Theory of Selectivity of label-free nanobiosensors; A geometro-physical perspective" *J. Appl. Phys.* 107, 064701 (2010).