

Optimal Methods for Fault Detection and Classification

Rasyidah Idris* and Nadzir Anas Lim

Faculty of Electrical Engineering, Universiti Teknologi Malaysia, 81310 UTM Skudai, Johor, Malaysia.

*Corresponding author: rasyidahidris@utm.my

Abstract: Detecting fault in transmission line is very important in order to have a well-functioned power system. This is due to the fact that the system will be distorted if there is fault in the transmission line. Occurrence of fault causes the significant difference in terms of the value of current or voltage in the system. There are a few approaches that can be used in order to detect and classify fault in the transmission line. Two methods of fault detection and classification have been used to be analyzed in order to identify both method accuracy and reliability. The two methods are the Wavelet Transform method and the Fuzzy Logic based method. Both methods show their own advantages and disadvantages after simulation have been done. These methods are later being utilized by combining both to create a better version of fault detection and classification method. In this paper, a combined method of Wavelet Transform and Fuzzy Logic based for fault detection and classification model for power systems is developed and simulated. This combined method is later compared to other method under the same category but different perspective and aspect namely the Radial Basis Function Neural Network. Fuzzy Logic Based method and Radial Basis Function Neural Network falls under Artificial Intelligence category for fault classification method. However, the approach used for both method is significantly different.

Keywords: fault, classification, transmission line, detection, fuzzy logic

© 2023 Penerbit UTM Press. All rights reserved

Article History: received 9 March 2023; accepted 9 April 2023; published 28 April 2023.

1. INTRODUCTION

The needs of electrical energy have been significant in this era especially due to the increasing number of populations. Thus, providing uninterrupted and sufficient power supply to the various types of consumers is very important. Power system is crucial for technological growth and considered as one of the vital needs nowadays. Generation, transmission and distribution are the three stages in power system. Transmission is one of the crucial stages in power system as it defines as movement of electrical energy from a generating site to electrical substations. The electrical power is later distributed to the consumers through the last stage of the process in power system, which is distribution. In these recent years where the population has increased drastically and technologies are one of the important aspects in life, the need of electricity is very demanding and essential. The ideal power system should be able to provide sufficient to the consumers without any interruptions and major failures. Unfortunately, several factors can cause the power system to be disrupted. One of these factors is faults. Faults occurs due to many factors such as lightning strikes, which falls under the natural disasters factor, human errors [1] and aging of the transmission line itself. Occurrence of fault is inevitable due the reasons mentioned. Faults can be categorized into balanced and unbalanced fault. Three phase fault is considered as balanced fault while unbalanced faults consist of single phase to ground, double phase, double

phase to ground fault. Listed below are the types of faults and their percentage of occurrence [2]:

- Single line to ground fault = 70% to 80%
- Line to line to ground fault = 10% to 17%
- Line to line fault = 8% to 10%
- Three phase faults = 2% to 3%

Fault causes the system to experience significant changes in terms of system quantities such as over-current, impedance, frequency, power or current direction. High fault current flows in the power system network due to short circuit, and it causes overheating and mechanical stress on the equipment of the power system [3].

The affected voltage and current signals in the system due to occurrence of fault are used to detect, locate and classify the fault in the system. Detecting, locating and classifying fault can be done by using several approaches where these methods are categorized under a few types. Some of the methods includes Wavelet Transform and Wavelet Packet Transform which categorized of signal processing techniques, Fuzzy logic based, Artificial Neural Network (ANN) and Radial Basis Function Neural Network (RBFNN) from Artificial Intelligence based techniques and the conventional methods that consists of impedance-based method and travelling wave-based method [4].

2. PROBLEM STATEMENT

Occurrence of faults in transmission line is one of the major problems in power system. These fault causes, the current and voltage waveforms contain significant high

frequency transient signals, which results, to disturbance in the normal working system, equipment failures and electric power supply interruption. Therefore, it is important to detect faults in the transmission line in order to protect the system and restore transient stability of the system. Detecting faults includes many kinds of approach. Wavelet method and fuzzy logic method are parts of the approach to detect faults in transmission line. Every approach has its own specific methods where each and one of them have their own advantage and disadvantage. In order to have a much more reliable and accurate approach, a model utilizing both methods can be used as well as finding another method with different aspects.

3. METHODOLOGY

The main objective is to detect and classify fault in a system. In order to apply and evaluate faults in the system, suitable test systems need to be designed where for this project, 1 test system is designed and used. This test system is 3-phase, 450V, 1100 km long transmission line. The long

transmission line will be connected with fault and fuzzy logic controller in order to detect and classify faults. Same goes to the implementation for radial basis function neural network, the same test system will be used. For this project, MATLAB Simulink is chosen as simulation platform to simulate both test system and apply both methods.

3.1 Combined Wavelet Transform method and Fuzzy logic-based method

As the name offers, the method consists of Wavelet Transform method and Fuzzy Logic method where Wavelet Transform method is used to detect fault while Fuzzy Logic method is used to classify fault. The analysis between these 2 methods before combination have already been analyzed beforehand. The result of the analysis shows that both methods have its own advantages as well as flaws which when the two methods are combined, a better approach to detect and classify fault can be created. Below is the model developed and simulated for the Combined Wavelet Transform method and Fuzzy logic-based method.

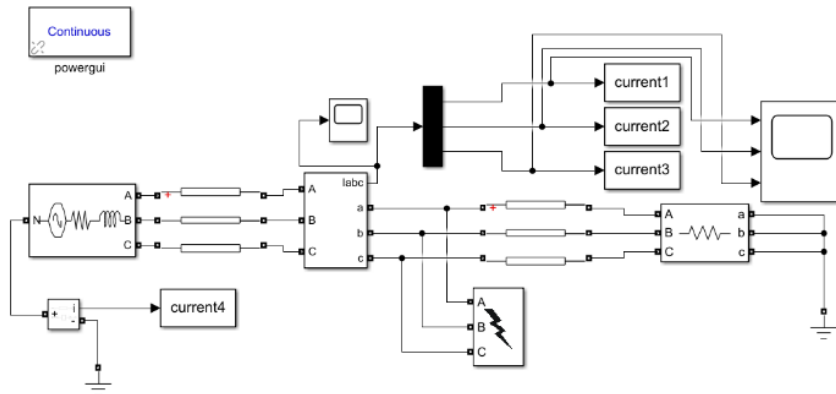

Figure 1. Model used for Combined Wavelet Transform and Radial Basis Function Neural Network.

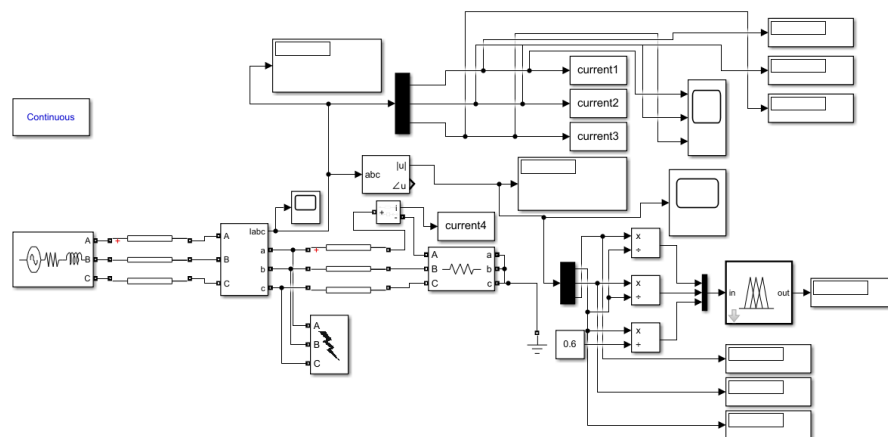

Figure 2. Model used for Combined Wavelet Transform and Fuzzy Logic Based method.

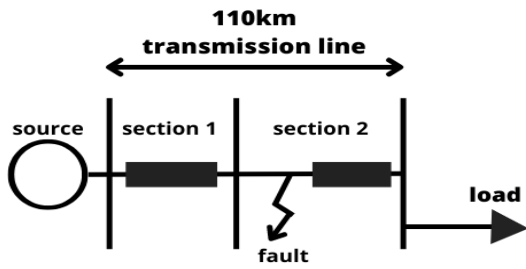

Figure 3. Single line diagram for the test system.

As specified, Wavelet Transform is used to detect fault in the system. Wavelet Transform, specifically Discrete Wavelet Transform (DWT) uses a time-scale representation of a discrete signal is obtained using digital filtering technique. The signal needed to be analyzed is passed through different filter having different cutoff frequency at different scales. The DWT is computed by successive low pass (h) and high pass (g) filtering of discrete time-domain signal. This is called as MALLAT algorithm. In first decomposition level, signal is decomposed into D1 and A1, with the frequency band of D1 and A1 is $f/2 - f/4$, $0 - f/4$. In the second decomposition, again the low pass filter, A1 is splitted into D2 and A2 with the frequency band of D2 is $f/4 - f/8$ and A2 is $0 - f/8$.

$$DWT(x, m, n) = \frac{1}{\sqrt{a_0^m}} \sum_m \sum_n x(k) \psi^* \left(\frac{k - nb_0 a_0^m}{a_0^m} \right)$$

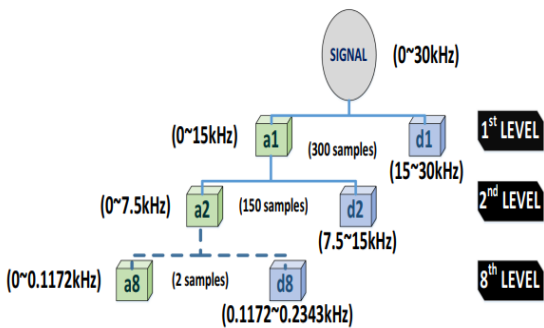

Figure 4. Decomposition of signal

The three-phase current signal of transmission line are taken as input and decomposed using discrete wavelet transform to obtain feature extraction.

Fuzzy logic-based method on the other hand is used for fault classification. Fuzzy logic-based method is a method that allows the system to categorized and make decision under the same perspective of the user. Instead of having only true and false, this method allows more elaborate and detail categorization which falls under the range between true and false such as very true, true, less true, mediocre, less false, false and very false. This pattern however is only accessible if the user feeds sufficient information to the statement [7]. Without proper experience and knowledge of the designated statement and system, the method can be inaccurate or even false.

Fuzzy logic works under the principle of ‘if-then’. It means that a rule, condition or statement needed to exist so that later actions can be executed if the conditions are meet.

Figure 5 shows the simple configuration of process flow of fuzzy logic.

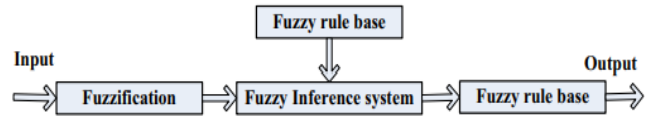
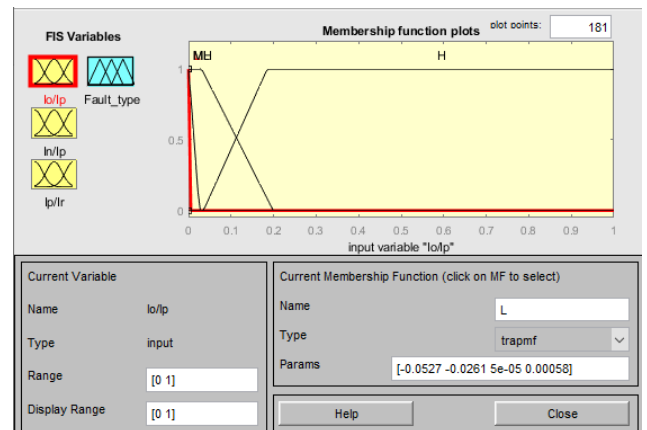

Figure 5: Fuzzy logic system process flow

This method is considered convenient as it has less burden in terms of computational burden [6].

A simple overall organization of a fuzzy scheme consists of fuzzification, fuzzy inference system, fuzzy rule base and defuzzification as displayed in Fig. 5 for fault classification. In the fuzzification stage, crisp numbers are mapped into fuzzy set. After fuzzification, the fuzzified inputs are given to the fuzzy inference system, and following the given fuzzy rule base, it gives the type of fault in its output. Finally, in the defuzzification stage, the fuzzy output set is mapped into crisp fault type.

Figure 5 show the membership function and rules created:



(a)

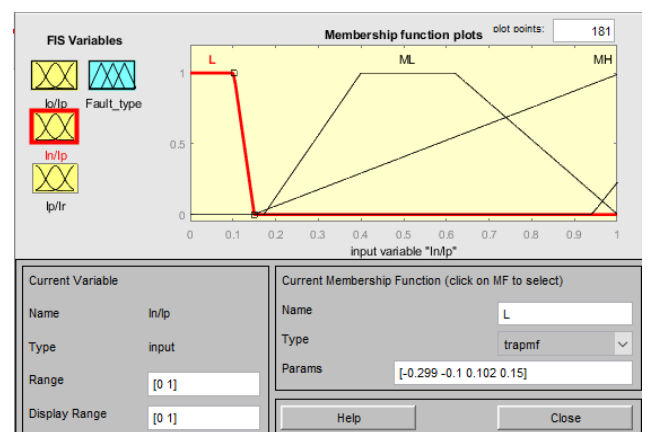

(b)

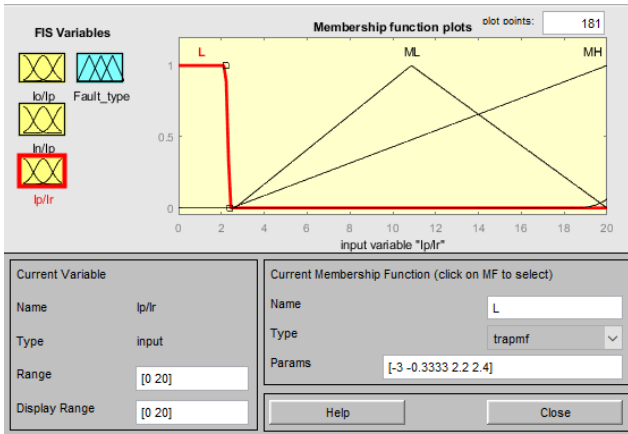

(c)

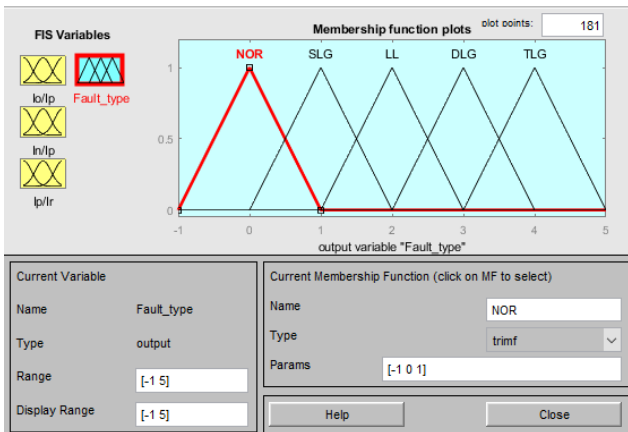

(d)

Figure 5. Membership functions

Combining both methods yields a much more reliable method to detect and classify fault as both methods' advantages are being utilized. The process of signal decomposition in Discrete Wavelet Transform to acquire the maximum coefficient of the input yields a value to recognize the significant difference between faulty and non-faulty inputs which in this paper is the phase current in the system. Thus, great in terms of detecting fault in the system. Besides, fuzzy logic method is great for fault classification due to its detail procedure in classifying the inputs by creating the membership function to distinguish the type of inputs in terms of its value which varies from low to medium to high and the creation of rules in fuzzy inference system where the inputs are classified by the types of faults through examining all three inputs value after the scanning through the membership function. The results later will be shown as values which resembles the types of faults in certain ranges.

3.2 Combined Wavelet Transform method and Radial Basis Function Neural Network

In this part of simulation, Wavelet Transform method is used in the same manner as previous simulation from Combined Wavelet Transform method and Fuzzy logic-based method which is for fault detection in the system. Then, the procedure proceeds with fault classification using Radial Basis Function Neural Network.

For fault detection, the data is analyzed using the previous procedure due its reliability in detecting significant difference in the input values to find fault in the system.

For fault classification using Radial Basis Function Neural Network, RBFNN contains 3 layers, and they are characterized by input, hidden and output layer. The input layer signals are given to the hidden layer where nonlinear radial basis function neuron action will take place, and linear neurons contain the output layer. Figure 6 shows the Radial Basis Function Neural Network architecture.

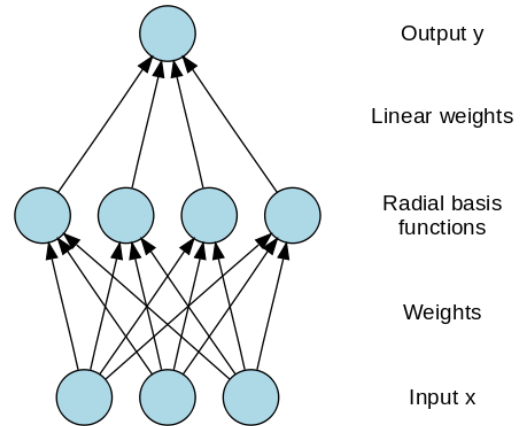

Figure 6. Radial Basis Function Neural Network architecture

There are 2 important components in this method. The method needs sufficient data so that it can reach certain accuracy. There are 2 types of data needed for the system to work properly. Those 2 types of data are training data and testing data. Training data are for the method to train and recognize the pattern of the input and distinguish between faulty and non-faulty inputs. The data should be above 100 in quantity in order to have better accuracy. In this step, a total of 108 data are used for training purposes. Training data includes inputs which are the values of all phase current in every case where all types are considered. The data also includes the representation of faulty and non-faulty inputs so that the method are able to recognize which data is faulty or not. These data consist of different types of ground fault in assessing all types of faults in order to collect as many data as possible. Below are the data used for training:

Ground fault resistance = 0.01

No.	Type of fault	Max coefficient of current (A)	Max coefficient of current (B)	Max coefficient of current (C)	Max coefficient of current (G)	Output value for phase A	Output value for phase B	Output value for phase C	Output value for phase G
1	None	0.0599	0.0700	0.0592	4.3938e-11	0	0	0	0
2	A-G fault	0.3223	0.0611	0.0630	0.3624	1	0	0	1
3	B-G fault	0.0626	0.3367	0.0630	0.3802	0	1	0	1
4	C-G fault	0.0889	0.0893	0.3943	0.3862	0	0	1	1
5	A-B fault	0.7043	0.9226	0.0672	1.5724e-05	1	1	0	0
6	A-C fault	0.7130	0.0700	0.7924	1.6358e-05	1	0	1	0
7	B-C fault	0.0599	1.4074	0.5789	1.1778e-05	0	1	1	0
8	AB-G fault	0.6343	0.6878	0.0691	0.2222	1	1	0	1
9	AC-G fault	0.4893	0.0611	0.4765	0.2377	1	0	1	1
10	BC-G fault	0.0626	0.7309	0.4077	0.2010	0	1	1	1
11	ABC fault	0.8967	0.9817	1.2827	5.8893e-07	1	1	1	0
12	ABC-G fault	1.1249	0.8260	1.2727	1.1566e-05	1	1	1	1

Ground fault resistance = 0.03

No.	Type of fault	Max coefficient of current (A)	Max coefficient of current (B)	Max coefficient of current (C)	Max coefficient of current (G)	Output value for phase A	Output value for phase B	Output value for phase C	Output value for phase G
1	None	0.0599	0.0700	0.0592	4.3938e-11	0	0	0	0
2	A-G fault	0.3249	0.0637	0.0453	0.3225	1	0	0	1
3	B-G fault	0.0751	0.4120	0.0424	0.3491	0	1	0	1
4	C-G fault	0.0751	0.0637	0.3276	0.3864	0	0	1	1
5	A-B fault	0.7043	0.9226	0.0672	1.5724e-05	1	1	0	0
6	A-C fault	0.7130	0.0700	0.7924	1.6358e-05	1	0	1	0
7	B-C fault	0.0599	1.4074	0.5789	1.1778e-05	0	1	1	0
8	AB-G fault	0.6073	0.4500	0.0522	0.1734	1	1	0	1
9	AC-G fault	0.7045	0.0637	0.6469	0.2179	1	0	1	1
10	BC-G fault	0.0751	0.4784	0.4920	0.1857	0	1	1	1
11	ABC fault	0.8967	0.9817	1.2827	5.8893e-07	1	1	1	0
12	ABC-G fault	1.1643	0.8260	1.6530	4.5174e-05	1	1	1	1

Ground fault resistance = 0.08

No.	Type of fault	Max coefficient of current (A)	Max coefficient of current (B)	Max coefficient of current (C)	Max coefficient of current (G)	Output value for phase A	Output value for phase B	Output value for phase C	Output value for phase G
1	None	0.0599	0.0700	0.0592	4.3938e-11	0	0	0	0
2	A-G fault	0.3354	0.0522	0.0584	0.3915	1	0	0	1
3	B-G fault	0.0989	0.3791	0.0982	0.3371	0	1	0	1
4	C-G fault	0.0917	0.0922	0.5296	0.3596	0	0	1	1
5	A-B fault	0.7043	0.9226	0.0672	1.5724e-05	1	1	0	0
6	A-C fault	0.7130	0.0700	0.7924	1.6358e-05	1	0	1	0
7	B-C fault	0.0599	1.4074	0.5789	1.1778e-05	0	1	1	0
8	AB-G fault	0.5676	0.5750	0.1069	0.2331	1	1	0	1
9	AC-G fault	0.5521	0.0693	0.7295	0.2637	1	0	1	1
10	BC-G fault	0.0468	0.3965	0.5240	0.2075	0	1	1	1
11	ABC fault	0.8967	0.9817	1.2827	5.8893e-07	1	1	1	0
12	ABC-G fault	0.7366	0.8957	1.3025	1.4609e-05	1	1	1	1

Ground fault resistance = 0.05

No.	Type of fault	Max coefficient of current (A)	Max coefficient of current (B)	Max coefficient of current (C)	Max coefficient of current (G)	Output value for phase A	Output value for phase B	Output value for phase C	Output value for phase G
1	None	0.0599	0.0700	0.0592	4.3938e-11	0	0	0	0
2	A-G fault	0.2914	0.0497	0.0657	0.3929	1	0	0	1
3	B-G fault	0.0500	0.3246	0.0592	0.3780	0	1	0	1
4	C-G fault	0.0565	0.0866	0.3014	0.5119	0	0	1	1
5	A-B fault	0.7043	0.9226	0.0672	1.5724e-05	1	1	0	0
6	A-C fault	0.7130	0.0700	0.7924	1.6358e-05	1	0	1	0
7	B-C fault	0.0599	1.4074	0.5789	1.1778e-05	0	1	1	0
8	AB-G fault	0.5789	0.6328	0.0528	0.2874	1	1	0	1
9	AC-G fault	0.6393	0.0497	0.8076	0.1532	1	0	1	1
10	BC-G fault	0.0416	0.7116	0.6563	0.1898	0	1	1	1
11	ABC fault	0.8967	0.9817	1.2827	5.8893e-07	1	1	1	0
12	ABC-G fault	1.3175	0.8160	1.2838	9.7303e-05	1	1	1	1

Ground fault resistance = 0.1

No.	Type of fault	Max coefficient of current (A)	Max coefficient of current (B)	Max coefficient of current (C)	Max coefficient of current (G)	Output value for phase A	Output value for phase B	Output value for phase C	Output value for phase G
1	None	0.0599	0.0700	0.0592	4.3938e-11	0	0	0	0
2	A-G fault	0.3358	0.0505	0.0593	0.3643	1	0	0	1
3	B-G fault	0.0723	0.2997	0.0561	0.3303	0	1	0	1
4	C-G fault	0.0723	0.0505	0.3738	0.3058	0	0	1	1
5	A-B fault	0.7043	0.9226	0.0672	1.5724e-05	1	1	0	0
6	A-C fault	0.7130	0.0700	0.7924	1.6358e-05	1	0	1	0
7	B-C fault	0.0599	1.4074	0.5789	1.1778e-05	0	1	1	0
8	AB-G fault	0.7690	0.4130	0.0561	0.2461	1	1	0	1
9	AC-G fault	0.4958	0.0505	0.7062	0.2585	1	0	1	1
10	BC-G fault	0.0723	0.5150	0.5885	0.2494	0	1	1	1
11	ABC fault	0.8967	0.9817	1.2827	5.8893e-07	1	1	1	0
12	ABC-G fault	1.0033	0.7391	1.2901	2.3726e-05	1	1	1	1

Ground fault resistance = 0.07

No.	Type of fault	Max coefficient of current (A)	Max coefficient of current (B)	Max coefficient of current (C)	Max coefficient of current (G)	Output value for phase A	Output value for phase B	Output value for phase C	Output value for phase G
1	None	0.0599	0.0700	0.0592	4.3938e-11	0	0	0	0
2	A-G fault	0.3527	0.0493	0.0495	0.3990	1	0	0	1
3	B-G fault	0.0628	0.4569	0.0484	0.4227	0	1	0	1
4	C-G fault	0.0998	0.0976	0.5345	0.3918	0	0	1	1
5	A-B fault	0.7043	0.9226	0.0672	1.5724e-05	1	1	0	0
6	A-C fault	0.7130	0.0700	0.7924	1.6358e-05	1	0	1	0
7	B-C fault	0.0599	1.4074	0.5789	1.1778e-05	0	1	1	0
8	AB-G fault	0.5595	0.8486	0.0892	0.2723	1	1	0	1
9	AC-G fault	0.6273	0.0569	0.5139	0.3197	1	0	1	1
10	BC-G fault	0.0460	0.4358	0.5088	0.1269	0	1	1	1
11	ABC fault	0.8967	0.9817	1.2827	5.8893e-07	1	1	1	0
12	ABC-G fault	0.9577	1.1090	0.7255	4.1728e-05	1	1	1	1

Ground fault resistance = 0.12

No.	Type of fault	Max coefficient of current (A)	Max coefficient of current (B)	Max coefficient of current (C)	Max coefficient of current (G)	Output value for phase A	Output value for phase B	Output value for phase C	Output value for phase G
1	None	0.0599	0.0700	0.0592	4.3938e-11	0	0	0	0
2	A-G fault	0.3812	0.0566	0.0629	0.3742	1	0	0	1
3	B-G fault	0.0987	0.3521	0.0981	0.4166	0	1	0	1
4	C-G fault	0.0584	0.0566	0.4784	0.2829	0	0	1	1
5	A-B fault	0.7043	0.9226	0.0672	1.5724e-05	1	1	0	0
6	A-C fault	0.7130	0.0700	0.7924	1.6358e-05	1	0	1	0
7	B-C fault	0.0599	1.4074	0.5789	1.1778e-05	0	1	1	0
8	AB-G fault	0.4750	0.4702	0.0629	0.2178	1	1	0	1
9	AC-G fault	0.6753	0.0566	0.5805	0.2330	1	0	1	1
10	BC-G fault	0.0584	0.5536	0.5533	0.1943	0	1	1	1
11	ABC fault	0.8967	0.9817	1.2827	5.8893e-07	1	1	1	0
12	ABC-G fault	0.5732	1.0446	0.8824	2.6157e-05	1	1	1	1

Ground fault resistance = 0.14

No.	Type of fault	Max coefficient of current (A)	Max coefficient of current (B)	Max coefficient of current (C)	Max coefficient of current (G)	Output value for phase A	Output value for phase B	Output value for phase C	Output value for phase G
1	None	0.0599	0.0700	0.0592	4.3938e-11	0	0	0	0
2	A-G fault	0.4161	0.0388	0.0394	0.2942	1	0	0	1
3	B-G fault	0.0485	0.4392	0.0453	0.2973	0	1	0	1
4	C-G fault	0.0573	0.0587	0.3491	0.4735	0	0	1	1
5	A-B fault	0.7043	0.9226	0.0672	1.5724e-05	1	1	0	0
6	A-C fault	0.7130	0.0700	0.7924	1.6358e-05	1	0	1	0
7	B-C fault	0.0599	1.4074	0.5789	1.1778e-05	0	1	1	0
8	AB-G fault	0.6550	0.5513	0.0550	0.2397	1	1	0	1
9	AC-G fault	0.5532	0.0455	0.6460	0.2294	1	0	1	1
10	BC-G fault	0.0485	0.9367	0.5089	0.1629	0	1	1	1
11	ABC fault	0.8967	0.9817	1.2827	5.8893e-07	1	1	1	0
12	ABC-G fault	0.8842	1.3366	0.6985	3.0824e-05	1	1	1	1

Ground fault resistance = 0.03

No.	Type of fault	Max coefficient of current (A)	Max coefficient of current (B)	Max coefficient of current (C)	Max coefficient of current (G)	Output value for phase A	Output value for phase B	Output value for phase C	Output value for phase G
1	None	0.0599	0.0700	0.0592	4.3938e-11	0	0	0	0
2	A-G fault	0.3249	0.0637	0.0453	0.3225	1	0	0	1
3	B-G fault	0.0751	0.4120	0.0424	0.3491	0	1	0	1
4	C-G fault	0.0751	0.0637	0.3276	0.3864	0	0	1	1
5	A-B fault	0.7043	0.9226	0.0672	1.5724e-05	1	1	0	0
6	A-C fault	0.7130	0.0700	0.7924	1.6358e-05	1	0	1	0
7	B-C fault	0.0599	1.4074	0.5789	1.1778e-05	0	1	1	0
8	AB-G fault	0.6073	0.4500	0.0522	0.1734	1	1	0	1
9	AC-G fault	0.7045	0.0637	0.6469	0.2179	1	0	1	1
10	BC-G fault	0.0751	0.4784	0.4920	0.1857	0	1	1	1
11	ABC fault	0.8967	0.9817	1.2827	5.8893e-07	1	1	1	0
12	ABC-G fault	1.1643	0.8260	1.6530	4.5174e-05	1	1	1	1

Ground fault resistance = 0.16

No.	Type of fault	Max coefficient of current (A)	Max coefficient of current (B)	Max coefficient of current (C)	Max coefficient of current (G)	Output value for phase A	Output value for phase B	Output value for phase C	Output value for phase G
1	None	0.0599	0.0700	0.0592	4.3938e-11	0	0	0	0
2	A-G fault	0.3433	0.0561	0.0666	0.4066	1	0	0	1
3	B-G fault	0.1019	0.4214	0.1003	0.2913	0	1	0	1
4	C-G fault	0.0667	0.0561	0.4589	0.3364	0	0	1	1
5	A-B fault	0.7043	0.9226	0.0672	1.5724e-05	1	1	0	0
6	A-C fault	0.7130	0.0700	0.7924	1.6358e-05	1	0	1	0
7	B-C fault	0.0599	1.4074	0.5789	1.1778e-05	0	1	1	0
8	AB-G fault	0.6329	0.6345	0.0735	0.2473	1	1	0	1
9	AC-G fault	0.4245	0.0793	0.6401	0.3520	1	0	1	1
10	BC-G fault	0.0667	0.6149	0.6673	0.1510	0	1	1	1
11	ABC fault	0.8967	0.9817	1.2827	5.8893e-07	1	1	1	0
12	ABC-G fault	1.6116e+10	2.6063e+09	8.5960e+09	25.7161	1	1	1	1

For testing data, a total of 30 data are used. The purpose of testing data is to show the accuracy of the method which in this case, the data of the system that need to identify if there is a fault or not. Below is the list of testing data used:

Ground fault resistance = 0.02

No.	Type of fault	Max coefficient of current (A)	Max coefficient of current (B)	Max coefficient of current (C)	Max coefficient of current (G)	Output value for phase A	Output value for phase B	Output value for phase C	Output value for phase G
1	None	0.0599	0.0700	0.0592	4.3938e-11	0	0	0	0
2	A-G fault	0.5207	0.0507	0.0689	0.4097	1	0	0	1
3	B-G fault	0.1472	0.4276	0.1467	0.3415	0	1	0	1
4	C-G fault	0.0448	0.0507	0.4215	0.4300	0	0	1	1
5	A-B fault	0.7043	0.9226	0.0672	1.5724e-05	1	1	0	0
6	A-C fault	0.7130	0.0700	0.7924	1.6358e-05	1	0	1	0
7	B-C fault	0.0599	1.4074	0.5789	1.1778e-05	0	1	1	0
8	AB-G fault	0.4992	0.4304	0.0689	0.2157	1	1	0	1
9	AC-G fault	0.4982	0.0507	0.5287	0.1760	1	0	1	1
10	BC-G fault	0.0636	0.4734	0.5080	0.2028	0	1	1	1
11	ABC fault	0.8967	0.9817	1.2827	5.8893e-07	1	1	1	0
12	ABC-G fault	0.7750	0.7527	1.3167	1.9815e-06	1	1	1	1

4. RESULT AND ANALYSIS

After both models have been simulated, each method's results are tabulated for analysis. The results consist of the inputs, outputs and the type of fault occurred in the system.

4.1 Combined Wavelet Transform method and Fuzzy logic-based method

The results show the capability of the combined method in detecting and classifying fault where Wavelet Transform method responsible to detect fault while Fuzzy Logic based method responsible to classify fault. Below are the tabulated results:

No.	Fault inserted	Fault detection	Output from Fuzzy logic	Types of faults exist
1	None	No	0.0003487	No fault @ Normal line
2	A-G fault	Yes	0.9991	Line to ground fault
3	B-G fault	Yes	0.9991	Line to ground fault
4	C-G fault	Yes	0.9992	Line to ground fault
5	A-B fault	Yes	2.367	Line to line fault
6	A-C fault	Yes	2.367	Line to line fault
7	B-C fault	Yes	2.367	Line to line fault
8	AB-G fault	Yes	2.556	Double line to ground
9	AC-G fault	Yes	2.556	Double line to ground
10	BC-G fault	Yes	2.556	Double line to ground
11	ABC fault	Yes	4	Line to line to line
12	ABC-G fault	Yes	4	Line to line to line to ground

Below is the indicator to identify type of fault in the system.

Range of values of output	Indication
-1 to 0.5	Normal line
0.5 to 1.5	Line to ground
1.5 to 2.5	Line to line
2.5 to 3.5	Double line to ground
3.5 to 5	Line to line to line to ground

4.2 Combined Wavelet Transform method and Radial Basis Function Neural Network

The results show the comparison between the input data which is the test data and the output which is the fault classification based on the method capability after training.

As shown in the results, it can be observed that both Combined Wavelet Transform method and Fuzzy Logic based method and Combined Wavelet Transform and Radial Basis Function Neural Network have the capability to detect and classify fault. The difference in these both methods are the approach they are using to acquire the results. For Combined Wavelet Transform and Fuzzy Logic based methods mostly relies on the user’s knowledge and experience regarding to the test system used. This is shown through their steps and procedure where in the creation of membership function and rules in the Fuzzy Logic based method are mostly rely on how the user define the parameters and the limits in order to have the method function properly and accurately. Differ from the first approach, Combined Wavelet Transform and Radial Basis Function Neural Network does not actually rely on the user’s understanding, knowledge and experience of the test system. Instead, the user will train the method using sufficient inputs. In this case, the inputs are the list of data related to all phase current during every type of faults. The users only need to determine the properties of the input in all cases where in this case, the faulty input will be assigned 1 while the non-faulty input will be assigned as 0. These sets of input data will be inserted into the method. The higher the quantity of the input data for training purposes, the higher the accuracy will be. This is due to the ability of the method to figure out and compare the inputs with the testing or the desired data for fault classification.

No.	Actual fault				Results of fault classification (RBFNN)			
	Actual Output Value for Phase A	Actual Output Value for Phase B	Actual Output Value for Phase C	Actual Output Value for Ground Current	RBFNN Output for Phase A	RBFNN Output for Phase B	RBFNN Output for Phase C	RBFNN Output for Phase D
1	0	0	0	0	0.0000	-0.0000	-0.0000	-0.0000
2	1	0	0	1	1.1584	0.0858	-0.1300	0.9815
3	0	1	0	1	0.1855	1.0032	-0.0971	0.9955
4	0	0	1	1	-0.0568	0.0297	1.0164	0.9868
5	1	1	0	0	1.0000	1.0000	-0.0000	-0.0000
6	1	0	1	0	1.0000	-0.0000	1.0000	-0.0000
7	0	1	1	0	0.0000	1.0000	1.0000	-0.0000
8	1	1	0	1	1.0536	0.9150	0.0057	1.0002
9	1	0	1	1	0.8229	-0.0876	1.1139	0.9248
10	0	1	1	1	0.0114	1.0090	0.9810	1.0007
11	1	1	1	0	1.0000	1.0000	1.0000	-0.0000
12	1	1	1	1	1.3212	1.0400	0.3237	1.4180
13	0	0	0	0	0.0000	-0.0000	-0.0000	-0.0000
14	1	0	0	1	1.0000	-0.0000	-0.0000	1.0000
15	0	1	0	1	0.0000	1.0000	-0.0000	1.0000
16	0	0	1	1	0.0000	-0.0000	1.0000	1.0000
17	1	1	0	0	1.0000	1.0000	-0.0000	-0.0000
18	1	0	1	0	1.0000	-0.0000	1.0000	-0.0000
19	0	1	1	0	0.0000	1.0000	1.0000	-0.0000
20	1	1	0	1	1.0000	1.0000	-0.0000	1.0000
21	1	0	1	1	1.0000	-0.0000	1.0000	1.0000
22	0	1	1	1	0.0000	1.0000	1.0000	1.0000
23	1	1	1	0	1.0000	1.0000	1.0000	-0.0000
24	1	1	1	1	1.0000	1.0000	1.0000	1.0000
25	0	0	0	0	0.0000	-0.0000	-0.0000	-0.0000
26	1	0	0	1	0.9858	-0.0030	-0.0298	0.9752
27	0	1	0	1	0.0585	1.1499	-0.1089	1.0230
28	0	0	1	1	0.0124	0.0219	0.9929	1.0002
29	1	1	0	0	1.0000	1.0000	-0.0000	-0.0000
30	1	0	1	0	1.0000	-0.0000	1.0000	-0.0000

5. CONCLUSION

In conclusion, both methods are great for fault detection and classification. Both methods managed to acquire correct output and show accurate results. The difference between the methods is the approach they take. The Combined Wavelet Transform and Radial Basis Function Neural Network have one advantages over the Combined Wavelet Transform and Fuzzy Logic based method as the method helps in simplify the steps for fault classification and does not rely too much on the user’s knowledge about the test system. Thus, Combined Wavelet Transform and Radial Basis Function Neural Network is preferable to be used in order to detect and classify fault due to its advantage.

REFERENCES

- [1] Manivannan, Preethi & Hapse, Manik. (2016). Fast and Accurate Fault Detection In Transmission Line using Wavelet Transform.
- [2] Wadha, C.L., 1998. Electrical power system, New Delhi: New Age International (p) Ltd.,
- [3] Crary SB (1947) Power system stability, vol 2. Wiley, New York
- [4] Mishra, D.P., Ray, P. Fault detection, location and classification of a transmission line. Neural Comput & Applic 30, 1377–1424 (2018). <https://doi.org/10.1007/s00521-017-3295-y>
- [5] Yadav A, Swetapadma A (2015) A novel transmission line relaying scheme for fault detection and classification using wavelet transform and linear discriminant analysis. Ain Shams Eng J 6:199–209.
- [6] Dash PK, Pradhan AK, Panda G (2000) A novel fuzzy neural network based distance relay scheme. IEEE Trans Power Deliv 15(3):902–907
- [7] P. Kumar, M. Jamil, M. S. Thomas and Moinuddin, "Fuzzy approach to fault classification for transmission line protection," Proceedings of IEEE. IEEE Region 10 Conference. TENCON 99. 'Multimedia Technology for Asia-Pacific Information Infrastructure' (Cat. No.99CH37030), 1999, pp. 1046-1050 vol.2, doi: 10.1109/TENCON.1999.818602.
- [8] IEA (2021), Net Zero by 2050, IEA, Paris <https://www.iea.org/reports/net-zero-by-2050>
- [9] Report on Peninsular Malaysia Generation Development Plan 2019 (2020–2030)
- [10] Bhatti, H.J. and Danilovic, M. (2018) Making the World More Sustainable: Enabling Localized Energy Generation and Distribution on Decentralized Smart Grid Systems. World Journal of Engineering and Technology, 6, 350-382.
- [11] T. Ackermann, G. Andersson, L. Söder, Distributed generation: a definition, Electric Power System Research. 57 (2001) 195–204.
- [12] Kuang, H., Li, S., & Wu, Z. (2011). Discussion on advantages and disadvantages of distributed generation connected to the grid. 2011 International Conference on Electrical and Control Engineering. <https://doi.org/10.1109/iceceng.2011.6057500>
- [13] X. Zhou, J. Liang, W. Zhou, X. Jin, Y. Tong and R. Cai, "Harmonic impacts of inverter-based distributed generations in low voltage distribution network," 2012 3rd IEEE International Symposium on Power

- Electronics for Distributed Generation Systems (PEDG), 2012, pp. 615-620, doi: 10.1109/PEDG.2012.6254066.
- [14] Dorigo, Marco & Maniezzo, Vittorio & Colomi, Alberto. (1999). Positive Feedback as a Search Strategy. Tech rep., 91-016, Dip Elettronica, Politecnico di Milano, Italy.
- [15] Teng, Jen-Hao & Chang, Chuo-Yean. (2007). Backward/Forward Sweep-Based Harmonic Analysis Method for Distribution Systems. Power Delivery, IEEE Transactions on. 22. 1665 - 1672. 10.1109/TPWRD.2007.899523.
- [16] Milovanović, Miloš & Radosavljević, Jordan & Klimenta, Dardan & Perovic, Bojan. (2019). GA-based approach for optimal placement and sizing of passive power filters to reduce harmonics in distorted radial distribution systems. Electrical Engineering. 101. 10.1007/s00202-019-00805-w